

LS C&S Busduct System

LT-way

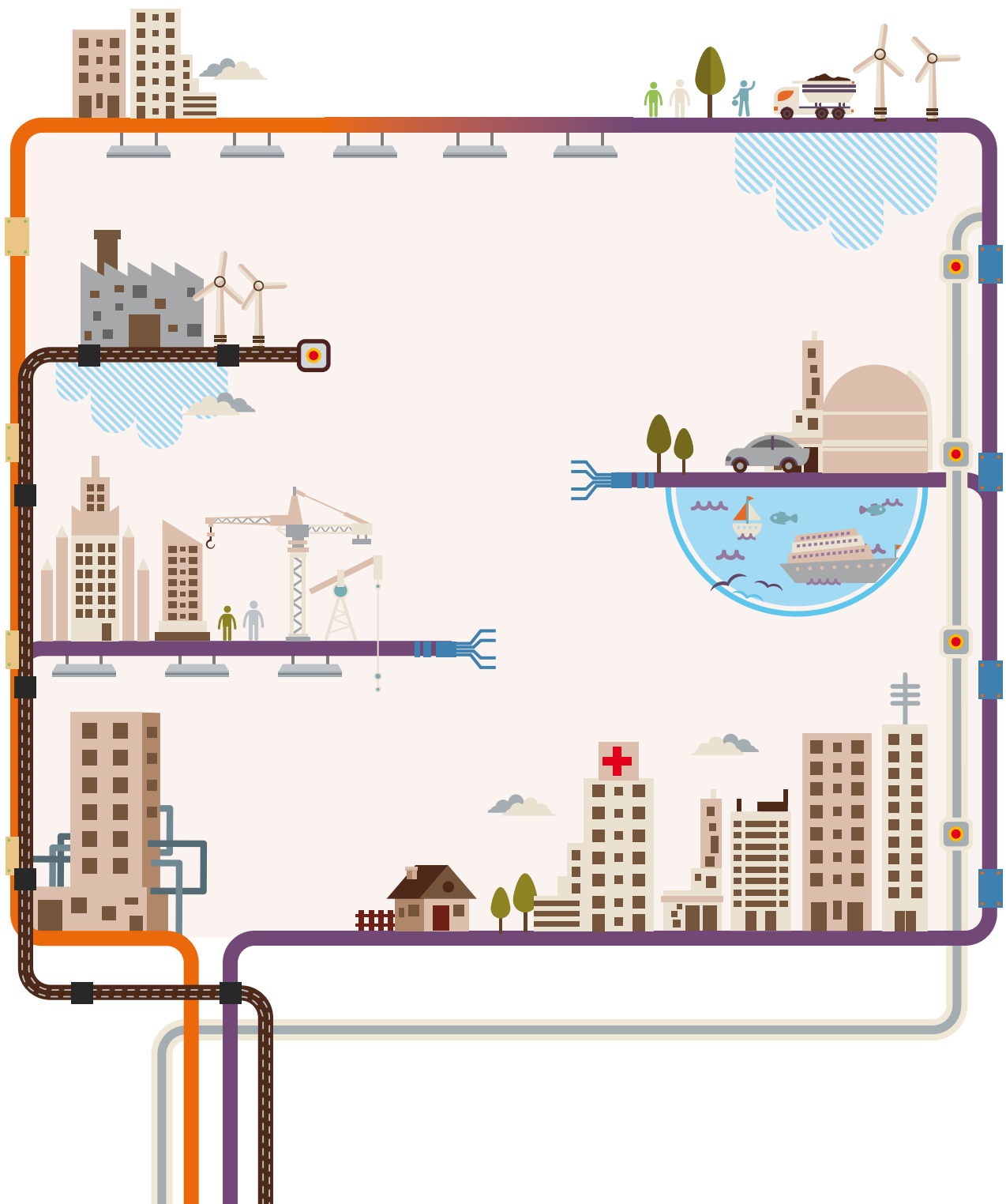

About LS Cable & System

Since the separation from LG Electronics in 2003, LS Group has specialized in industrial energy, electronic energy, and industrial materials. Thus, LS Group has achieved specialized global competitiveness in these fields. LS Group is a parent company of 40 subsidiary companies, including LS Cable & System, LSIS, LS Nikko Copper, LS Mtron, Gaon Cable, E1 and Yesco. LS Cable & System holds the unrivaled position of the top cable maker in Korea, and it provides total solutions for electronic power and telecommunication industries.

LS Cable & System has strived to become a global leader in the industry by implementing constant innovation since the establishment of the company. While providing high-quality solutions to help our clients, LS Cable & System is accelerating efforts to be the top player of the global cable industry by securing the top technologies in submarine cables and superconducting cables, as well as focusing on green business. Under the company vision 'Your No.1 Creative Partner', LS Cable & System dedicates its best effort to deliver only the top technology and service to its clients.



A New Beginning as a Total Solution Provider for Electric Power and Telecommunications

History was made when LS Cable & System, the de facto holding company of LS Group, transformed into LS Holding Company in July 2008 and started as a new total-solution provider specialized in electric power and telecommunications. It was the optimized business decision to increase management efficiency of the constantly expanding business segments and to strengthen the responsible management system to foster a new growth engine to drive our business.

By separating investment and business segments, LS Holdings was able to discover a new growth engine to propel the group into a new phase of growth. The new change of business provided an opportunity to the subsidiary companies to focus on their own operations and to strengthen their respective business expertise, as well as successfully enhancing the competitiveness in the industry. LS Cable & System, as the holding company, is committed to providing continued support to the subsidiary companies, while practicing responsible management. LS Cable & System endeavor to focus on our core business while strengthening its business expertise and competitiveness as a global company.

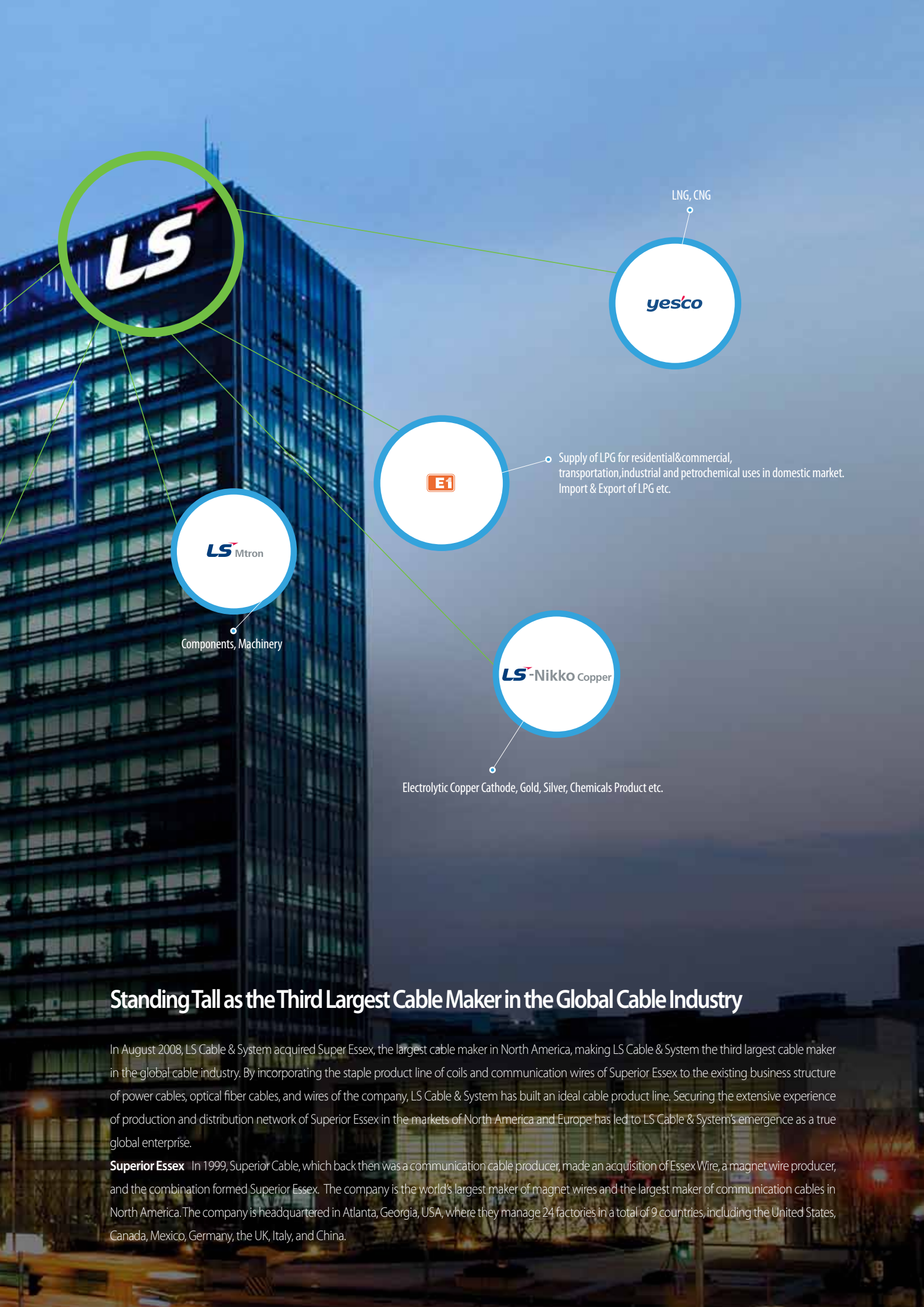

LNG, CNG

Supply of LPG for residential & commercial, transportation, industrial and petrochemical uses in domestic market. Import & Export of LPG etc.

Components, Machinery

Electrolytic Copper Cathode, Gold, Silver, Chemicals Product etc.

Standing Tall as the Third Largest Cable Maker in the Global Cable Industry

In August 2008, LS Cable & System acquired Super Essex, the largest cable maker in North America, making LS Cable & System the third largest cable maker in the global cable industry. By incorporating the staple product line of coils and communication wires of Superior Essex to the existing business structure of power cables, optical fiber cables, and wires of the company, LS Cable & System has built an ideal cable product line. Securing the extensive experience of production and distribution network of Superior Essex in the markets of North America and Europe has led to LS Cable & System's emergence as a true global enterprise.

Superior Essex In 1999, Superior Cable, which back then was a communication cable producer, made an acquisition of Essex Wire, a magnet wire producer, and the combination formed Superior Essex. The company is the world's largest maker of magnet wires and the largest maker of communication cables in North America. The company is headquartered in Atlanta, Georgia, USA, where they manage 24 factories in a total of 9 countries, including the United States, Canada, Mexico, Germany, the UK, Italy, and China.



LS Cable & System
Leading Solution

LS Cable & System Busduct System Solution



Buildings

The LS C&S Busduct system is easy to install, and ensures large capacity of energy transmission while providing space efficiency which makes the bus duct system ideal for high-rise buildings, office buildings, data centers and apartment complexes.



Plants

The full lineup is consisting of NSPB, CAST RESIN and SIB that can cover up to 27kv, and the lineup thus enables us to provide our clients customized designs. The system is suitable for electrical rooms and power lines, and it features a real time monitoring system using the temperature and power monitoring system.



Data Center

The flexibility and expandability as well as easy maintenance property of the busduct system provides the best alternative to improve the existing problems of the conventional power cable system of data centers, which requires constant extension, reinstallation and capacity modification of loads.



Apartment Buildings

Although the demands for more electricity for families are growing, the space for EPS area has reduced. Due to the change, the need for busducts and multi boxes have increased.



Hospitals

The stability of the power supply in the hospitals is perhaps the most vital element, because its failure could threaten the safety of patients.

The Busduct system distributes larger capacity of electric power, and provides stability of the loads which make it an ideal choice to satisfy the requirements of systematization of hospital complexes and larger hospital equipments.



Airports

In order to secure the stable power supply of the airport, the busduct system provides the best customized solutions by installing high voltage busducts at the transmission, transformation and power distribution lines, and by installing low voltage busducts at the cargo, the control tower and general commercial buildings.



Stadiums

The needs for a busducts system has been growing for its benefit such as large capacity of power transmission, providing a stable power supply for various loads and an eco friendly property as well as economical quality.



Marine & Wind

The compact and light weight design of the busduct satisfies the demands of the clients, and comes with an outstanding quack resistance property. The busduct provides stability to the operation of the facilities through a real-time monitoring system using a temperature and power monitoring system. As the needs for renewable energy grows, the demand for our busduct has been increasing steadily.

LS Cable & System Busduct Product Line-up

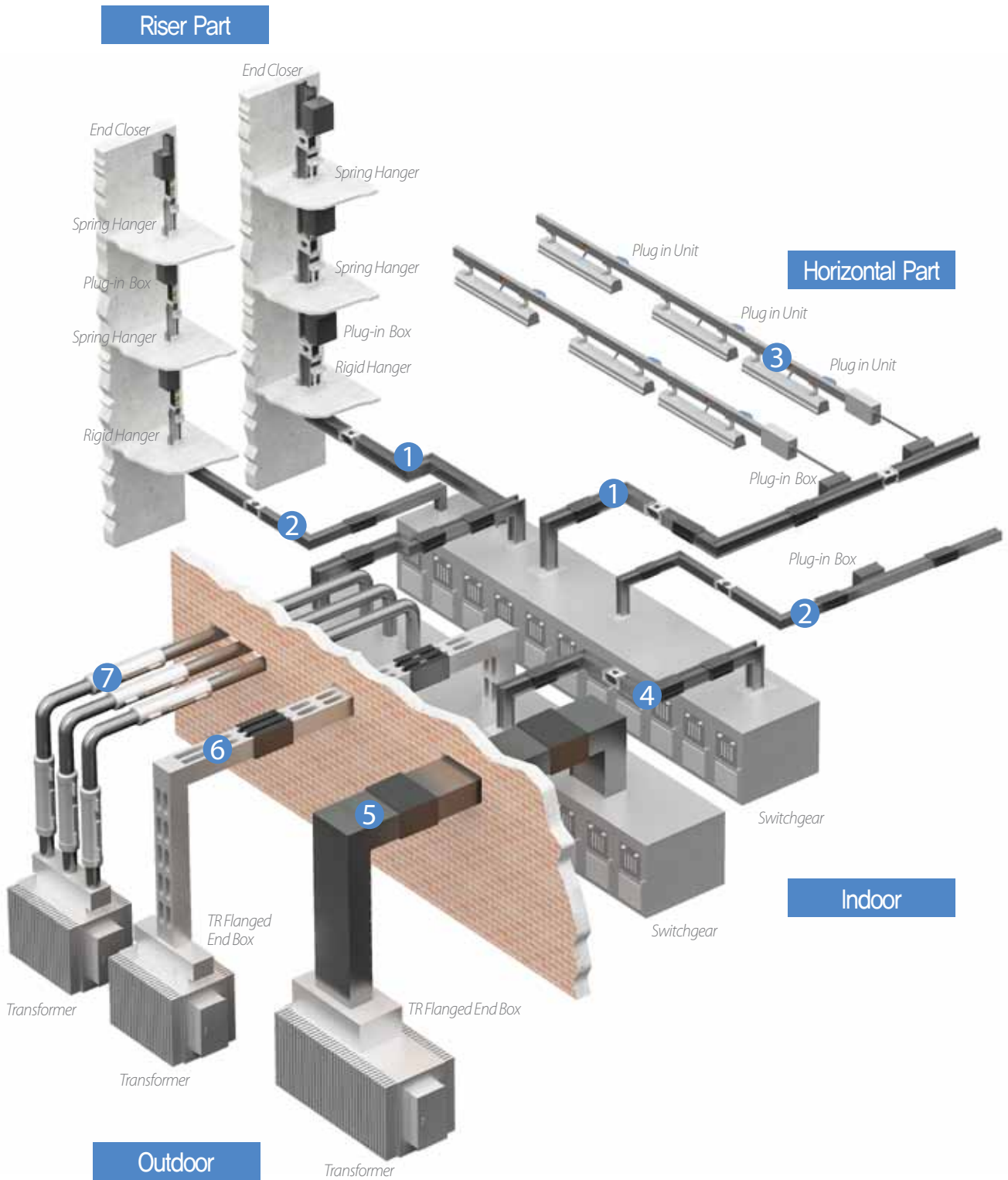

The LS Cable & System Busducts are available in a wide range of products from low current capacity LT-way (25A~63A) to large current capacity (630A~7500A), and the products enable the supply of proper capacity of power for factories and the distribution system. Our products such as the air insulated bus conducts with enhanced safety property and the cast resin busducts with resistance for high temperature, humidity and dusty environment will satisfy various application needs and provide a customized engineering service.

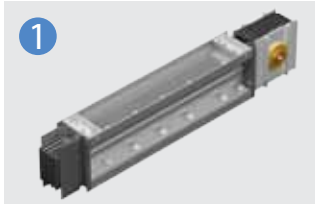

1

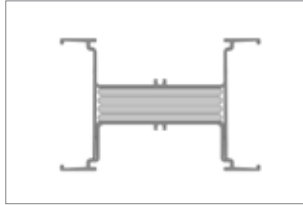

Ez/Ex/Ef-way

Sandwich Type (PET Film, Epoxy Coating, MICA)/AL Extrusion Housing/Standard IP54/Joint Kit

- Designed for low voltage products below AC 1000V, and between 630A to 7500A.
- The most widely used conventional model.

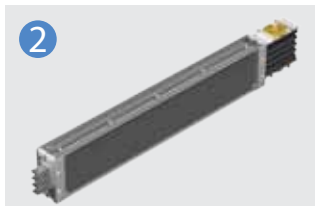

2

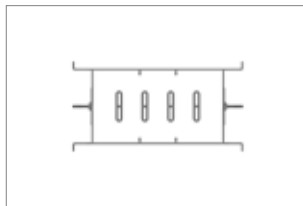

Mini-way

Air Insulated Type/AL Extrusion Housing/Standard IP54/Joint Kit

- Designed for low voltage products below AC 1000V, and between 160A and 800A.
- Ideal for small distribution system with multi distribution loads (Vertical areas of buildings, data centers, assemble factories)



3

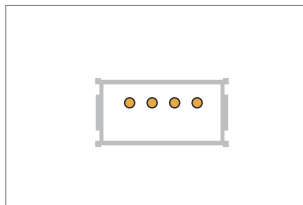

LT-way

Flat Wire Type/Copper Conductor with PVC Extruded Insulation/AL Extrusion Housing/Various Plug Types/Joint Brush (It can be installed with a live wire.)

- Designed for low voltage products below AC 690V, and between 25A and 63A
- Suitable for Light bulbs, FFU and distribution for small equipments



4



MS/Wind-way

Air Insulated Type/ Compact NSPB Type / One-Bolting Type Designed for low voltage products below AC 1000V, and between 1000A and 5000A

- A Hybrid incorporating NSPB and sandwich type
- Ideal for ships, wind towers and chemical plants where stability is required.



5

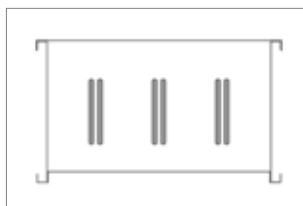

NSPB-LV/MV

Air Insulated Type/Insulated conductors separated by phase/AL, STS and Steel Housing (optional)/Indoor Type/Outdoor Type

- NSPB-LV : Designed for low voltage products below AC 1000V, and below 4000A
- NSPB-MV: Designed for high voltage products below AC 27kV, and below 4000A
- Suitable for plants where high stability is required.



6



CR-LV/MV

- Cast Resin Type/IP 68/Epoxy Molding between Conductors

- CR-LV: Designed for low voltage products below AC 1000V, and between 630A and 7500A.
- CR-MV: Designed for high voltage products below AC 27KV, and below 5000A.
- The most safe bus duct suitable for plants where high stability is required.



7

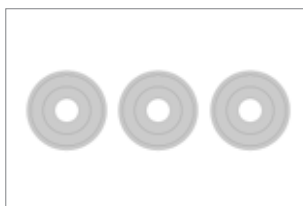

SIB

Epoxy Vacuum impregnated insulation Products/Suitable for phase separation system

- Designed for high voltage products below AC 27kV and below 7500A
- Small space , bending area
- Suitable for high voltage products.

Why Busduct?

Easy Distribution of Loads

When supplying power using cables, each load has to be connected individually to cables which waste space, and an additional distribution panel is also required.

On the other hand, busducts are separated from a single line at a plug box which simplifies the electric power system. A MCCB can be installed at the plug box to effectively shut off fault current.

Cable Wiring System

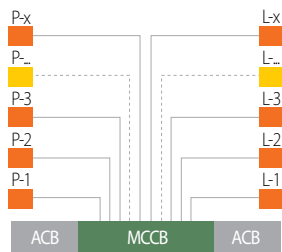

- One-to-one correspondence of power supply and loads
- Additional lines are needed in case of a load change

Busduct Wiring System

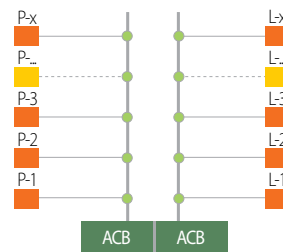

- One-to-many correspondence of power supply for specific power supply
- Additional lines are not necessary in case of a load change

ACB : Air Circuit Breaker, MCCB : Molded Case Circuit Breaker

Easy Installation

Pulling and cable tray installation for cables can be difficult, and requires a longer construction period, therefore increases the cost. On the other hand, the busducts use a simple installation method to connect specific length of products, which requires a shorter installation period, and is economically friendly.

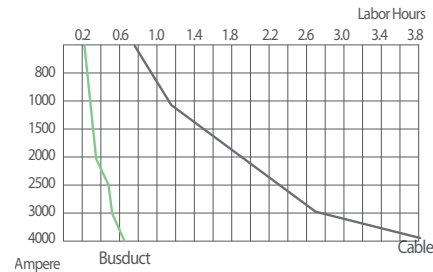

Compact

The compact design of the busduct system provides high space efficiency at up to 50% compared to the cables. While cables require larger space to install multi lines as well as additional space for coiling areas, the busducts use proper fittings to maximize space efficiency.

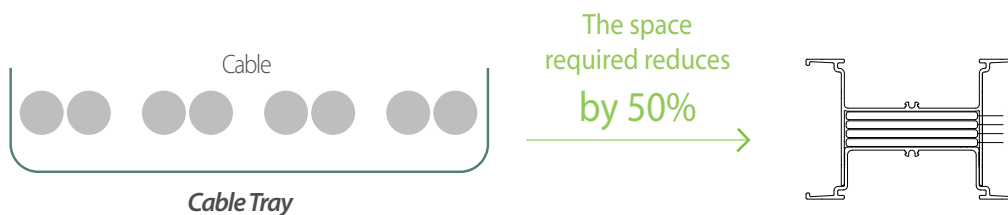

Adaptability to various installation environment with convenience

The busduct system is a power distribution system and can be applied to various complex routes. The busduct system comes with various fittings such as elbow, off-set and tee, and can transmit high capacity currents without electrical and mechanical loss.

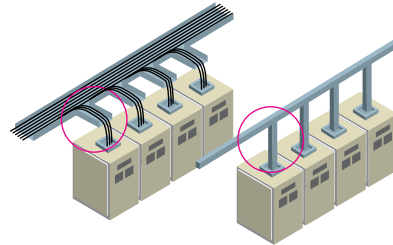

Excellent short circuit

The busduct system has a high tolerance for short circuit. Its stability and reliability make it perfect for a high capacity energy transmission system.

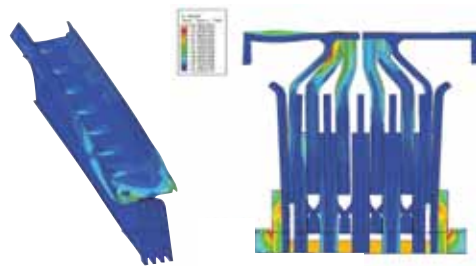

High current density

Cables are connected directly to electric loads using racks. Its maximum allowable current ampacity limit is 1000A, and requires additional lines for a higher current. Each line of the busduct system can transmit up to 7500A, and provides high current density.

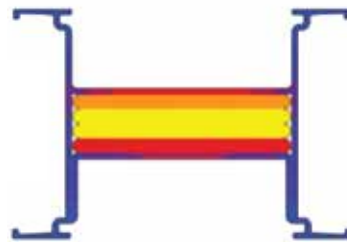

Easy maintenance

The design of the busduct system makes it easy to detect abnormalities during installations, and ensures easy maintenance. When humidity or dust causes a malfunction on the system, the easy-to-maintain design allows replacing only the damaged part.

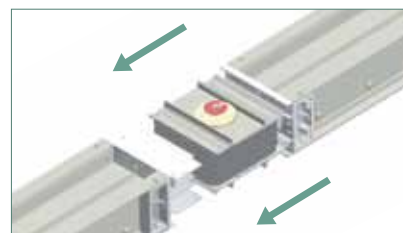

Outstanding features of EMC and EMI

Unlike cables, the busduct system does not require a shield, instead Busduct, the housing itself performs as a shield which enhances the features of EMC and EMI.



Why LS Cable & System Busduct

Global Top Tier

LS Cable & System has been a long-time leading Busduct provider in Korea. With extensive experience and product line competitiveness, the company provides total solutions for each application to satisfy the needs of its clients. Using its expertise in the electronic markets of large LCD monitors and semiconductors in Korea, the company has obtained PJT sales records in 50 countries worldwide in Asia, the Middle East, CIS, and America.

Full Line - up

LS Cable & System is the only global company that provides a full line-up of busducts, from low to high voltage and from low to high capacity, to satisfy every need of its clients and provide an optimized solution for each PJT.

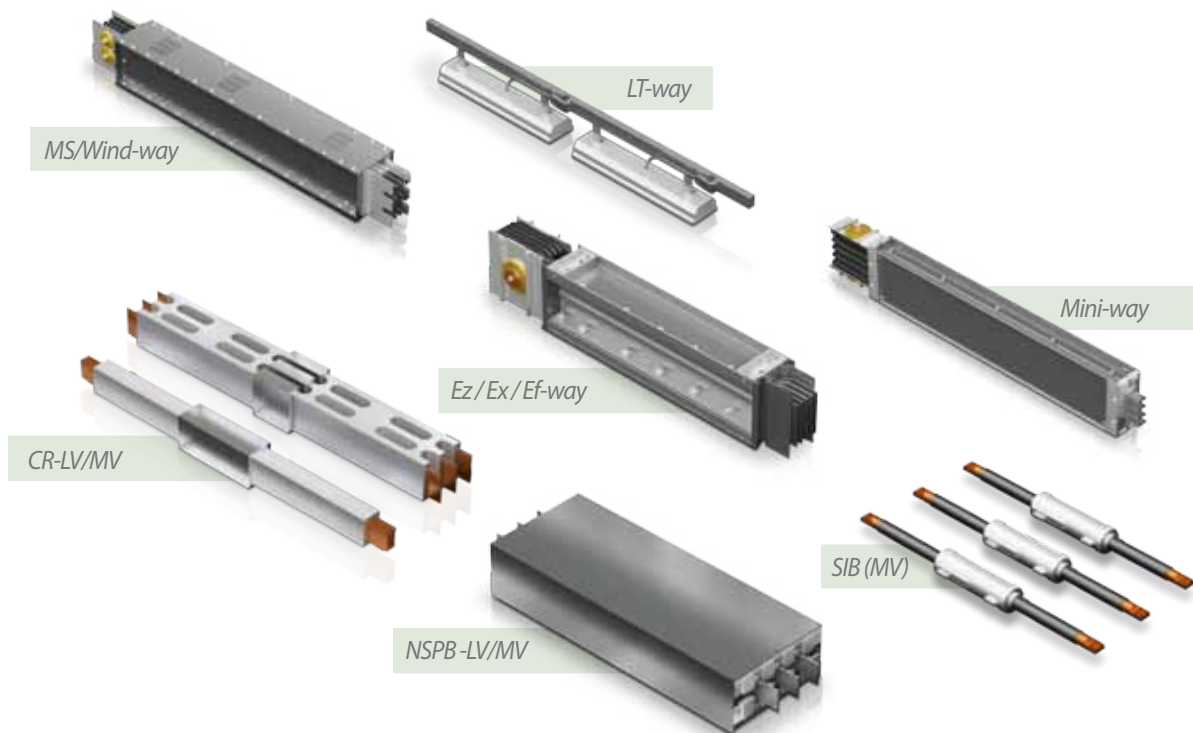

Total Solution

- Once PJT launches, our engineer will participate to guide the clients from the initial period in order to produce the best system for our clients, and to respond quickly when the system is changed.
- Our engineers from each department provide full support in design, production, installation and testing at in-bound to satisfy our clients.
- We operate the CS Team, a task force for the busduct system, to make sure efficient after-sale service and maintenance service.

Process

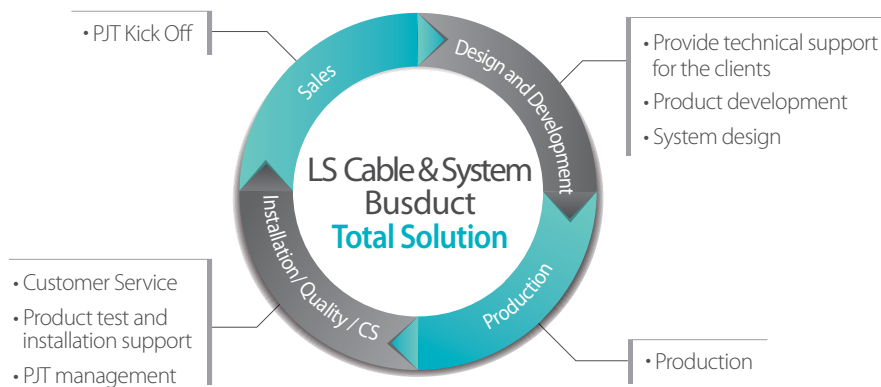

Technical Excellence

Unparalleled Reliability

- Provides standardized design, and owns numerous certifications such as UL Certification, Quack Proof Certification, and Impact Resistance Certification
- The CS team, a task force for the busduct system, provides efficient after-sale service
- Safe use in hazardous zones
- Manage the system using a unique temperature monitor sensor
- Semi-permanent service life
- Used qualified insulation such as epoxy and PET film for efficient insulation

Eco friendly

- Fully recyclable
- Halogen free
- Does not contain RoHS 6 hazardous substance
- No toxicity in fire & Fire-Retardant
- Non Explosive

Total Engineering Technology

- Provide the optimal design by experienced engineers
- Design following analysis and inspection of CAE
- Unique and exclusive design program for the busduct system
- Design based on structure stability inspection
- The excellent heat –radiating property of the aluminum housing, which ensures large capacity of power transmission
- Low Weight & Low cost
- Easy installation
- Deployable where access is difficult
- Automated epoxy insulation facility
- Unique joint kit connections
- Reduce electromagnetic
- BPMS (Busduct Power Monitoring system)
- BTMS (Busduct Temperature Monitoring system)

The Busduct Temperature Monitoring System (BTMS : Busduct Temperature Monitoring System)

The busduct is a large capacity power distribution system. The insulation of the duct has to stay stable when the Joule lines occur during a power supply of the conductor. The rated current will be set by the insulation type and the temperature rises. These properties of the busduct make it possible to monitor and manage abnormalities of the system by checking the temperature of specific areas of the system.

The temperature monitoring system uses various temperature sensors such as optical fiber cable, IC electric chips and thermo-graphic cameras. Specific areas like the entire system line, joints, plug-in boxes and cable connection can be monitored at the central monitor room using various methods on request.

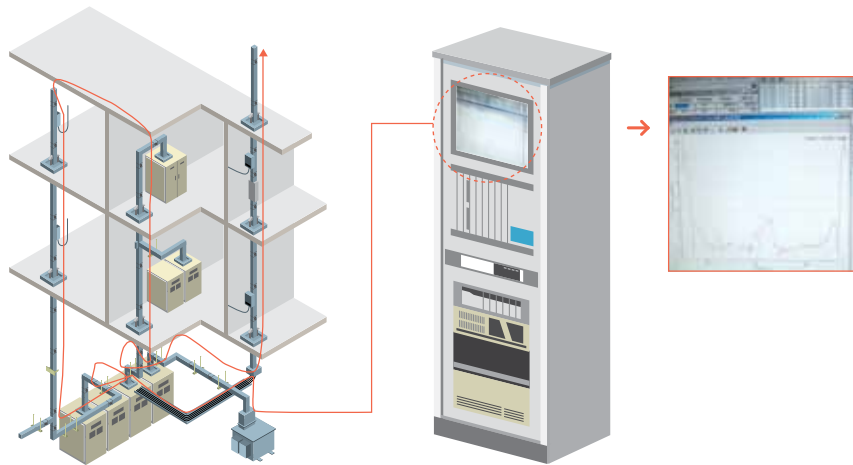

The Busduct Power Monitoring System (BPMS : Busduct Power Monitoring System)

The ongoing trends of the busduct system are more than a simple power supplying system. The growing trend is; 1) the stability of the power system, 2) unmanned system, 3) cost cutting, and 4) green and smart grid. While the SCADA system monitors and controls the power of the main system, the BMS monitors low loads of the sub system. The frequency of the recent electrical accidents is higher at the sub system than at the main system. Therefore, the preference for the BMS system has been increasing.

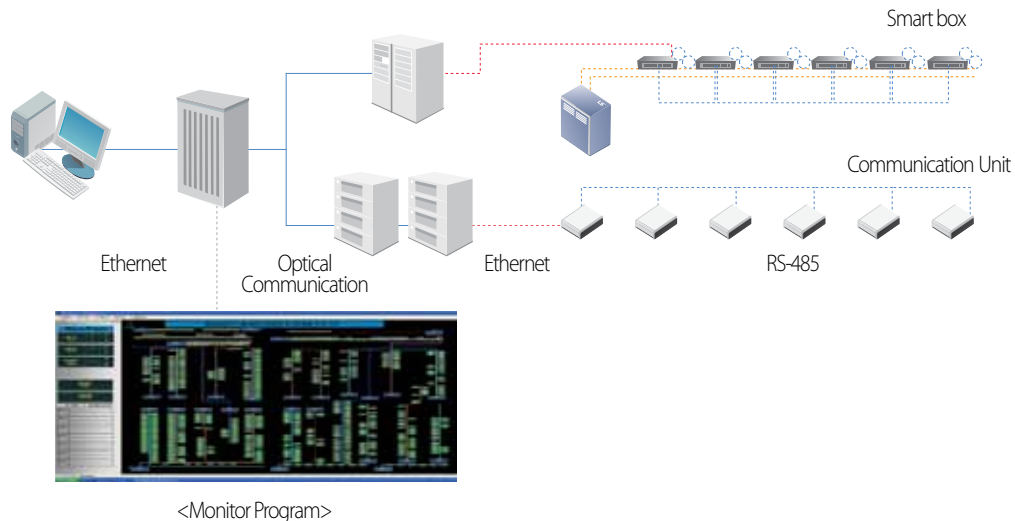

LT-WAY

LS C&S Busduct System Catalogue

03 of 08

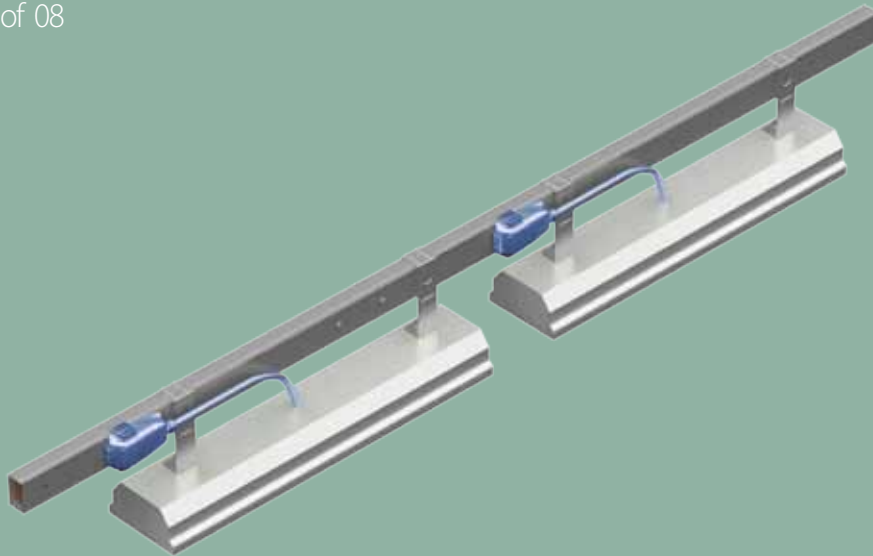

Contents

I. Introduction	
- Overview	14
- Application	15
II. General Data	16
III. Component	
- Feeder	19
- Feed in Unit	22
- Flexible Fitting	23
- End Cover	24
- Hanger	24
- Plug In Unit	25
IV. Technical Data	
- Impedance	26
- Voltage Drop	26
- Temperature Rise	27
V. Install Information	
- Joint Connection	28
- Plug-in Unit Installation	28
VI. Certification & Specification	29

Overview

About LT-way

LS C&S LT-way is designed for small capacity loads of 25 to 63A such as lamp circuits. It is also designed to blend in well with the existing facilities, while providing the optimum power supply system. The LT-way comes with the optimized cross sectional areas as well as stable design of conductors and housing, which provide efficient heat-radiating property specified in IEC heat regulations. The LT-way also comes with a high degree of protection with standard IP54. The design can be applied in a special environment such as greenhouses and clean-rooms. Its adaptability to frequent alterations of a layout makes it a perfect product.

Safe and Efficient Distribution System

LS C&S LT-way is designed for small lines or lamp circuits at buildings, factories and shopping malls. The plug and the outlet attached to the LT-way provide easy management of load distribution.

Eco-Friendly

The LS C&S LT-way is an environmentally friendly product following the RoHS regulation, and only uses components without hazardous substances.

Easy Installation

The light weight of LS C&S LT-way enables easy transportation and installation, and employing the joint brush system makes it easy to take apart and assemble. The plug-in load distribution provides easier maintenance and installation compare to cables.

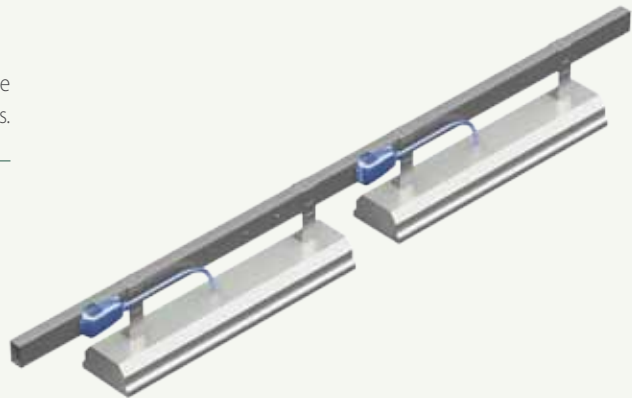

Application



Supermarkets / Shopping Mall etc.

- Can be used as lighting system in the store.

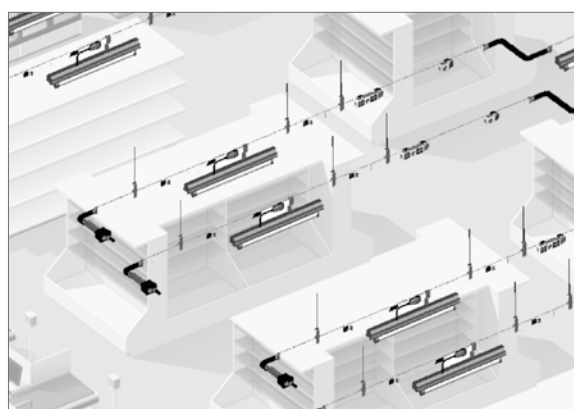

Factory etc.

- Can be used as lighting system for production lines.
- Excellent flexibility and adaptability to layout changes.

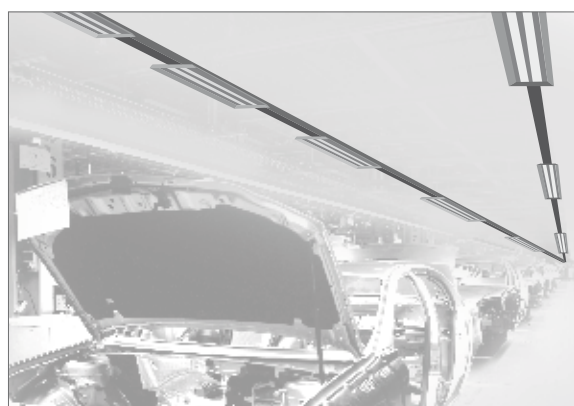

Basement Parking etc.

- Can be used as lighting system for basement parking space of large buildings, apartments and commercial complexes.



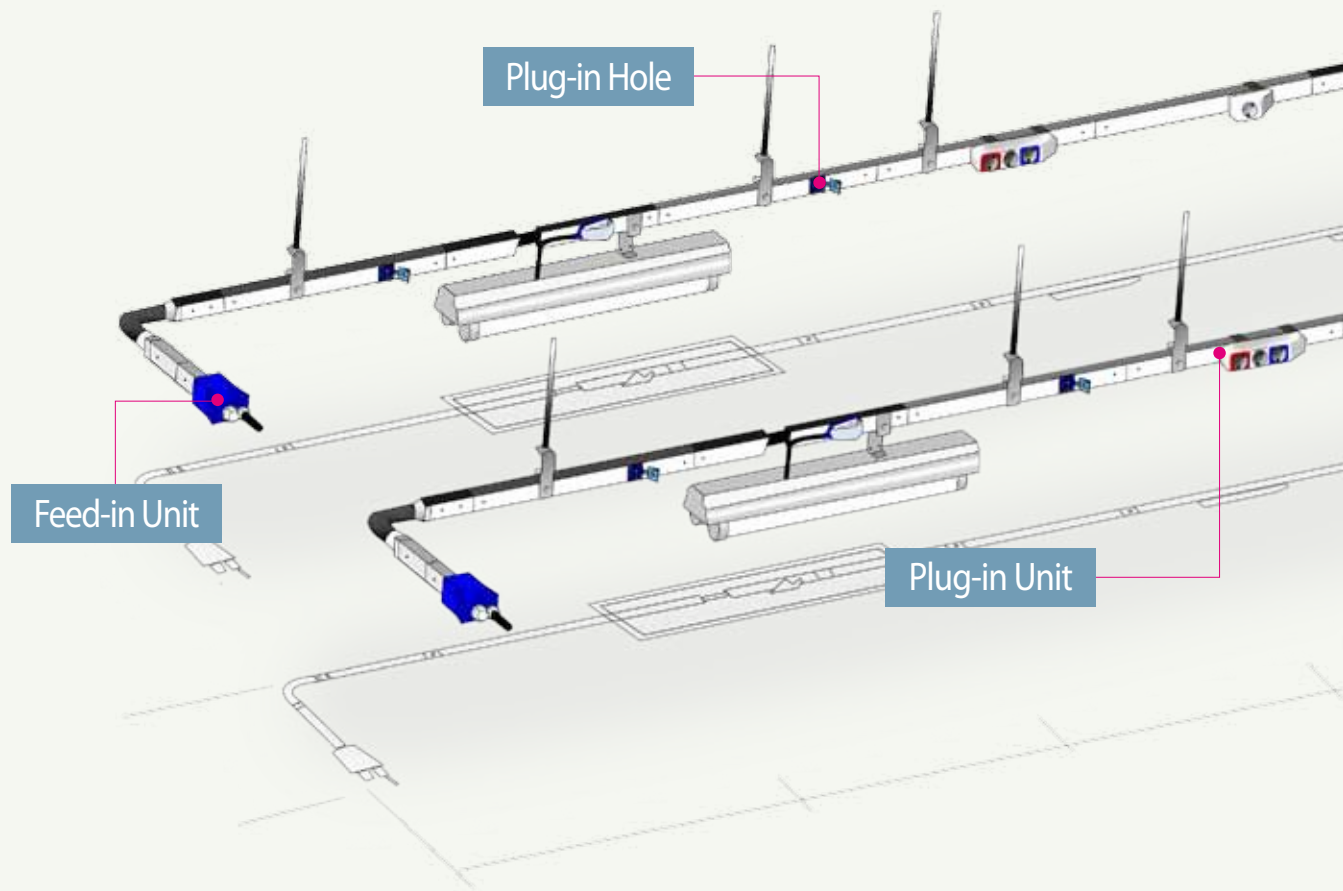

Weight

The compact and light weight design of extruded aluminum housing is suitable for low capacity power lines between 25 to 63A.



Eco Friendly

The LS C&S Busducts acquired RoHS certification, and only uses components without hazardous substances such as lead, cadmium, mercury, chrome, PBBs and PBDEs.



Easy Load Distribution

Each feeder (3 meters) can have a maximum 10 load distributions installed, and provide them easily.



Standard

- IEC 61439-1 [(previous standard)IEC 60439-1] Power Switchgear and Controlgear Assemblies
- IEC 61439-6 [(previous standard)IEC 60439-2] Busbar Trunking Systems



Permissible Operating Temperature

The cross sectional areas of the conductor and housing profile are designed to meet the standard permissible operating temperature of IEC 61439-1 and 6. Therefore the temperature rise limit of the housing is within 55K or less of the ambient temperature.



Service Condition

- Ambient Temperature : -15 °C ~ 55 °C
 - Relative Humidity : 95% or below
- (When the service condition of the environment does not meet the requirements listed above, please contact our design team.)

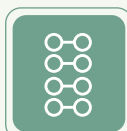
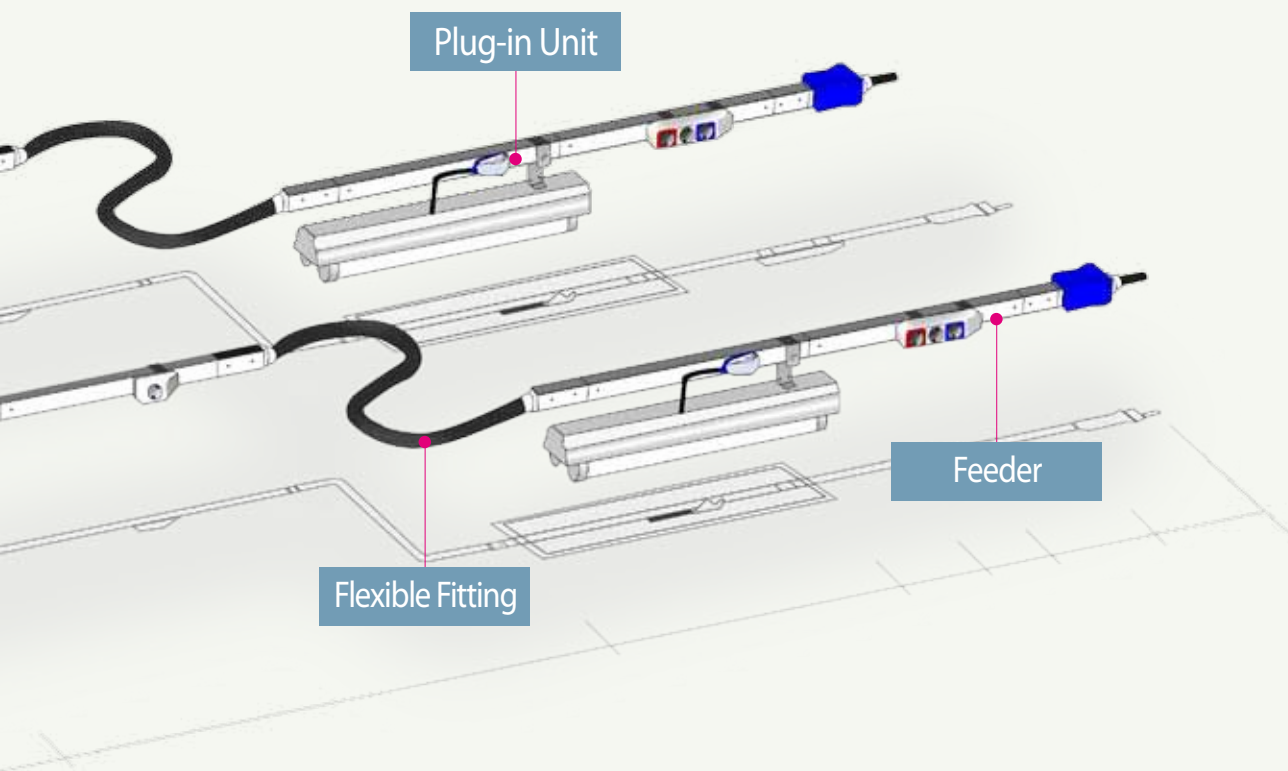

Conductors

The conductor uses over 99 percent pure copper flat wire consisting of 2 or 4 fibers. Elongated marks have been etched in order to prevent slips when pressed. The LT-way comes with high molecule insulation of a fire proof grade A rating. The intervals between insulations have been designed for the optimum functionality as specified in CAE (Computer Aided Engineering).



Housing

The high strength aluminum housing can be used as a protective conductor (PE) due to its high level conductivity and mechanical strength. Variety of coating options for the housing is available on request.

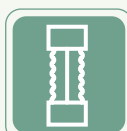

Insulation

Other than the connections and the PH, the conductor has been insulated which prevent accidents caused by impacts. The insulation uses PVC which has the fire proof grade A rating (105°C) according to IEC regulations.



Joint Brush

The Joint brush can be safely and easily connected with a live wire. Optional double cover is available. The double enhances the strength against impacts.

Basic Structure

LT-way comes with flat-wire, and suitable for small loads or lamp loads of 690V 25 to 63A. Each phase has been wrapped with PVC, an electric insulation with an A rating (fire proof grade 105 °C) or higher, and the same rating insulation supports them.

Configuration

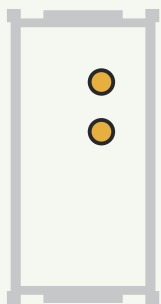

Phase : (PH + N + PE)
 Wire : 2
 Tier : 1

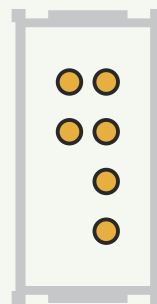

Phase : (3PH + N + PE)
 (PH + N + PE)
 Wire : 6
 Tier : 2

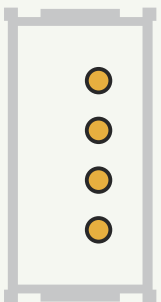

Phase : (3PH + N + PE)
 Wire : 4
 Tier : 1

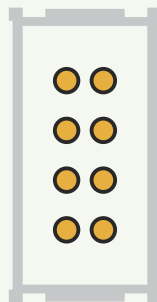

Phase : (3PH + N + PE) x 2
 Wire : 8
 Tier : 2

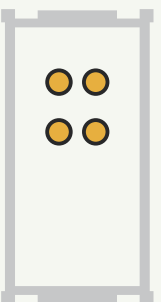

Phase : (PH + N + PE) x 2
 Wire : 4
 Tier : 2

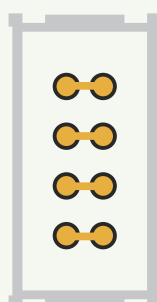

Phase : (3PH + N + PE)
 Wire : 4
 Tier : 2

*It only applies to the special capacity (63A).

Feeder

The standard length of feeders is either 3 meters or 1.5 meters, and 5 plug-in holes can be applied on each side of a 3 meter feeder (maximum 10 holes). For a 1.5 meter feeder, 3 plug-in holes can be applied on each side (maximum 6 holes).

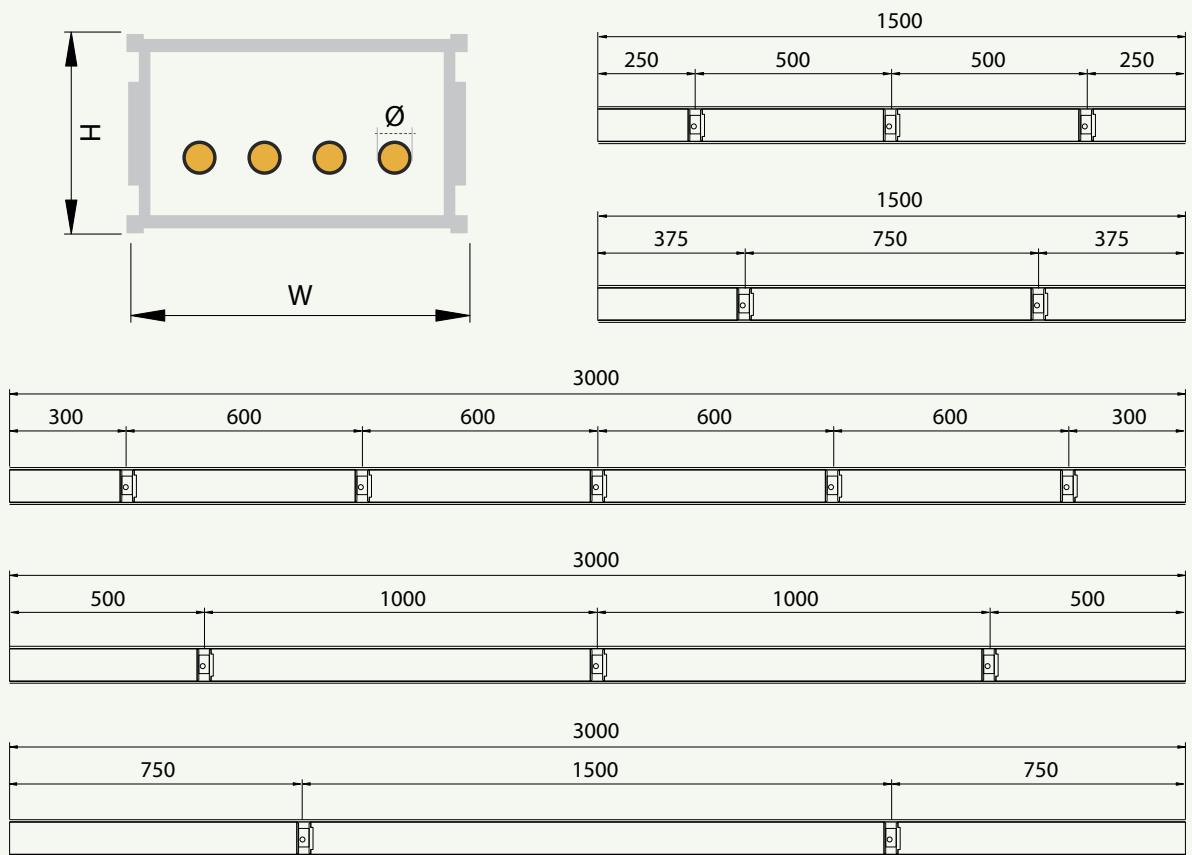
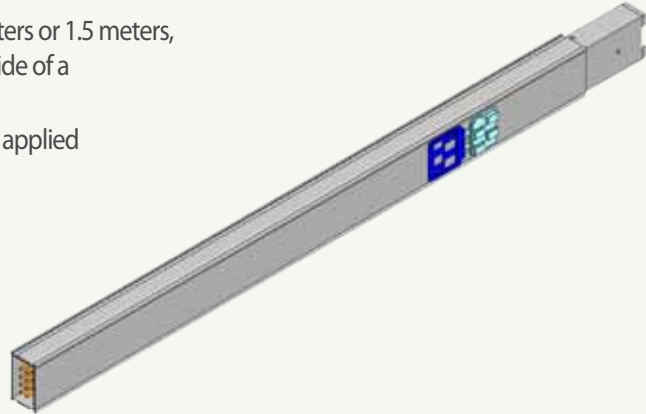

Ampere(A)		Dimension(mm)		
		H	W	Φ
CU	25	30	50	1.8
	40			2.8
	63			2.8

Feeder

A single housing can handle two lines (R, S, T, N X 2), and the 3-phase 4-wire system supplies larger capacity than a single phase which decrease the line imbalance.

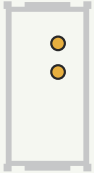
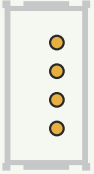
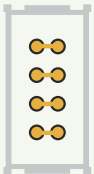
Configuration	Ampere	Wire	Tier	Length	Plug-in hole	Weight	Cat No.
	A	W	Tier	mm	EA	g/m	No.
STD. Feeder (Ph + N + PE) 	25	2	1	3000	0	2355	LSLT F252130
	25	2	1	3000	2		LSLT F252132
	25	2	1	3000	3		LSLT F252133
	25	2	1	3000	5		LSLT F252135
	25	2	1	1500	2	1260	LSLT F252112
	2	2	1	1500	3		LSLT F252113
	40	2	1	3000	0	2520	LSLT F402130
	40	2	1	3000	2		LSLT F402132
	40	2	1	3000	3		LSLT F402133
	40	2	1	3000	5		LSLT F402135
	40	2	1	1500	2	1340	LSLT F402112
	40	2	1	1500	3		LSLT F402113
STD. Feeder (3Ph + N + PE) 	25	4	1	3000	0	2615	LSLT F254130
	25	4	1	3000	2		LSLT F254132
	25	4	1	3000	3		LSLT F254133
	25	4	1	3000	5		LSLT F254135
	25	4	1	1500	2	1390	LSLT F254112
	25	4	1	1500	3		LSLT F254113
	40	4	1	3000	0	2970	LSLT F404130
	40	4	1	3000	2		LSLT F404132
	40	4	1	3000	3		LSLT F404133
	40	4	1	3000	4		LSLT F404134
	40	4	1	3000	5		LSLT F404135
	40	4	1	1500	2	1565	LSLT F404112
40	4	1	1500	3	LSLT F404113		
STD. Feeder (3Ph+N+PE) 	63	4	1	3000	0	3860	LSLTF634130
	63	4	1	3000	2		LSLTF634132
	63	4	1	3000	3		LSLTF634133
	63	4	1	1500	5		LSLTF634135
	63	4	1	1500	2	2010	LSLTF634112
	63	4	1	3000	3		LSLTF634113

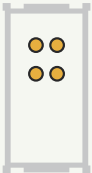
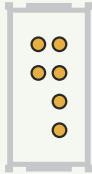
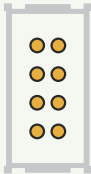
Configuration	Ampere	Wire	Tier	Length	Plug-in hole	Weight	Cat No.
	A	W	Tier	mm	EA	g/m	No.
STD. Feeder (Ph + N + PE) x 2 	25	6	2	3000	0	2615	LSLT F256230
	25	6	2	3000	2		LSLT F256232
	25	6	2	3000	3		LSLT F256233
	25	6	2	3000	5		LSLT F256235
	25	6	2	1500	2	1390	LSLT F256212
	25	6	2	1500	3		LSLT F256213
	40	6	2	3000	0	2970	LSLT F406230
	40	6	2	3000	2		LSLT F406232
	40	6	2	3000	3		LSLT F406233
	40	6	2	3000	5		LSLT F406235
	40	6	2	1500	2	1565	LSLT F406212
	40	6	2	1500	3		LSLT F406213
STD. Feeder (3Ph + N + PE)(Ph + N + PE) 	25	6	2	3000	0	2890	LSLT F256230
	25	6	2	3000	2		LSLT F256232
	25	6	2	3000	3		LSLT F256233
	25	6	2	3000	5		LSLT F256235
	25	6	2	1500	2	1525	LSLT F256212
	25	6	2	1500	3		LSLT F256213
	40	6	2	3000	0	3415	LSLT F406230
	40	6	2	3000	2		LSLT F406232
	40	6	2	3000	3		LSLT F406233
	40	6	2	3000	5		LSLT F406235
	40	6	2	1500	2	1790	LSLT F406212
	40	6	2	1500	3		LSLT F406213
STD. Feeder (3Ph + N + PE) x 2 	25	8	2	3000	0	3175	LSLT F258230
	25	8	2	3000	2		LSLT F258232
	25	8	2	3000	3		LSLT F258233
	25	8	2	3000	5		LSLT F258235
	25	8	2	1500	2	1670	LSLT F258212
	25	8	2	1500	3		LSLT F258213
	40	8	2	3000	0	3860	LSLT F408230
	40	8	2	3000	2		LSLT F408232
	40	8	2	3000	3		LSLT F408233
	40	8	2	3000	5		LSLT F408235
	40	8	2	1500	2	2010	LSLT F408212
	40	8	2	1500	3		LSLT F408213

Feed in Unit

The feed in unit connects cables and the LT-way. It can connect a maximum 10mm² and is used at the opening and ending points of source and load system.

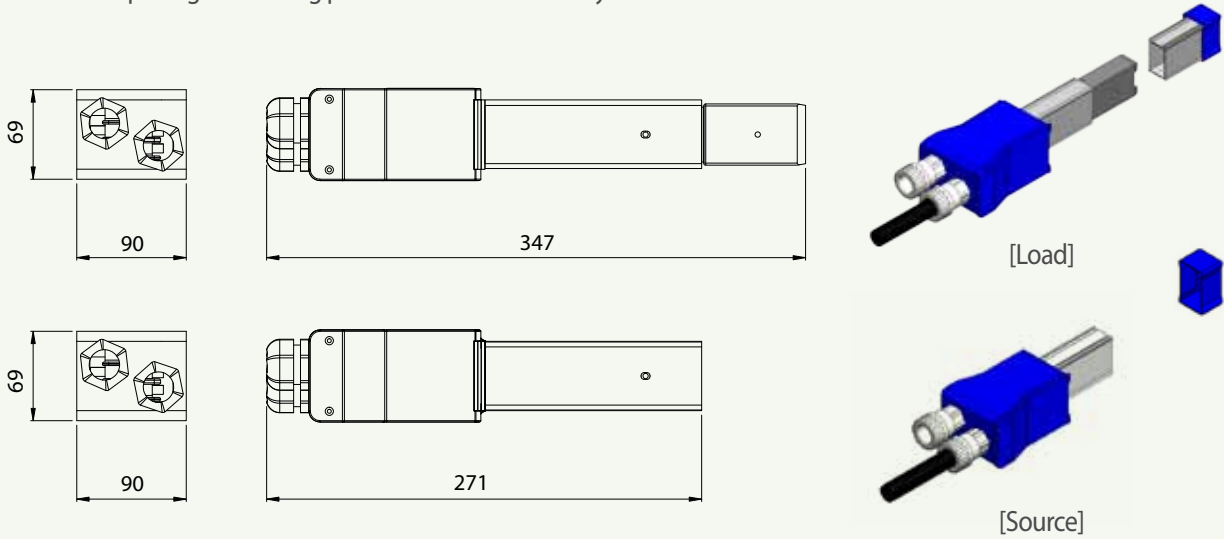

Configuration	Ampere A	Wire W	Tier Tier	Source/Load	Weight g/m	Cat No. No.
				Source/Load		
STD. Feeder (Ph + N + PE)	25	2	1	Source	500	LSLT U2521S
	25	2	1	Load	600	LSLT U2521L
	40	2	1	Source	515	LSLT U4021S
	40	2	1	Load	515	LSLT U4021L
STD. Feeder (3Ph + N + PE)	25	4	1	Source	515	LSLT U2541S
	25	4	1	Load	515	LSLT U2541L
	40	4	1	Source	550	LSLT U4041S
	40	4	1	Load	550	LSLT U4041L
	63	4	1	Source	615	LSLTU6341S
	63	4	1	Load	615	LSLTU6341L
STD. Feeder (Ph + N + PE) x 2	25	4	2	Source	515	LSLT U2542S
	25	4	2	Load	515	LSLT U2542L
	40	4	2	Source	550	LSLT U4042S
	40	4	2	Load	550	LSLT U4042L
STD. Feeder (3Ph + N + PE) (Ph + N + PE)	25	6	2	Source	530	LSLT U2562S
	25	6	2	Load	530	LSLT U2562L
	40	6	2	Source	580	LSLT U4062S
	40	6	2	Load	580	LSLT U4062L
STD. Feeder (3Ph + N + PE) x 2	25	8	2	Source	545	LSLT U2582S
	25	8	2	Load	545	LSLT U2582L
	40	8	2	Source	615	LSLT U4082S
	40	8	2	Load	615	LSLT U4082L

Flexible Fitting

The flexible fitting rotates 180° and is used to adjust the height or bypass a route. The fixing method is the same as the feeder and the standard length is 0.5m and 1m.

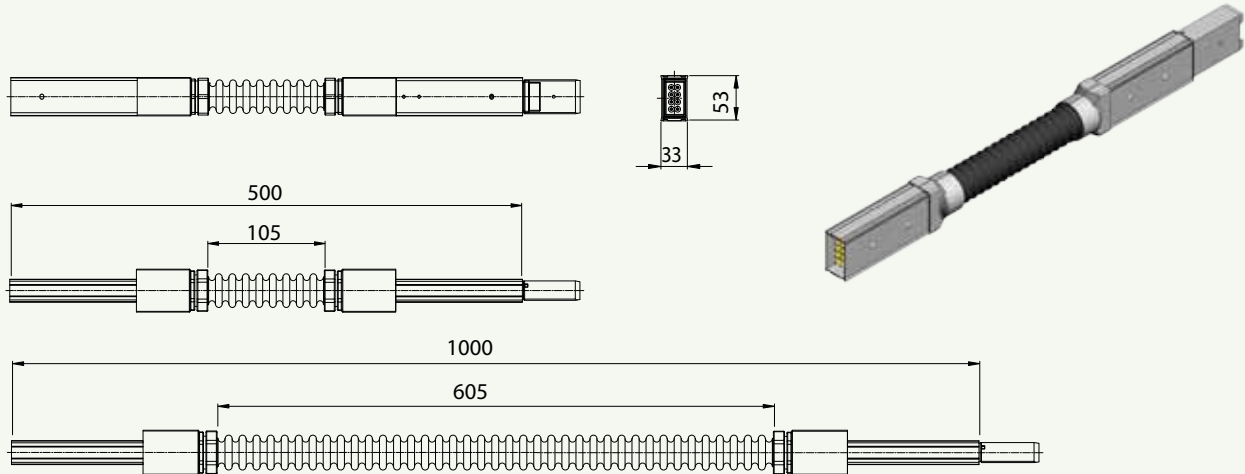

Configuration	Ampere A	Wire W	Tier Tier	Length mm	Weight g/m	Cat No.
						No.
STD. Feeder (Ph + N + PE)	25	2	1	500	585	LSLT X25210
	25	2	1	1000	1010	LSLT X25211
	40	2	1	500	610	LSLT X40210
	40	2	1	1000	1060	LSLT X40211
STD. Feeder (3Ph + N + PE)	25	4	1	500	630	LSLT X25410
	25	4	1	1000	1100	LSLT X25411
	40	4	1	500	615	LSLT X40410
	40	4	1	1000	1195	LSLT X40411
	63	4	1	500	815	LSLTX63410
STD. Feeder (Ph + N + PE) x 2	63	4	1	1000	1465	LSLTU63411
	25	4	2	500	630	LSLT X25420
	25	4	2	1000	1110	LSLT X25421
	40	4	2	500	615	LSLT X40420
	40	4	2	1000	1195	LSLT X40421
STD. Feeder (3Ph + N + PE) (Ph + N + PE)	25	6	2	500	675	LSLT X25620
	25	6	2	1000	1185	LSLT X25621
	40	6	2	500	745	LSLT X40620
	40	6	2	1000	1330	LSLT X40621
STD. Feeder (3Ph + N + PE) x 2	25	8	2	500	720	LSLT X25820
	25	8	2	1000	1275	LSLT X25821
	40	8	2	500	815	LSLT X40820
	40	8	2	1000	1465	LSLT X40821

End Cover

The end cover is applied at the end of a rail, and is the same for all capacities.

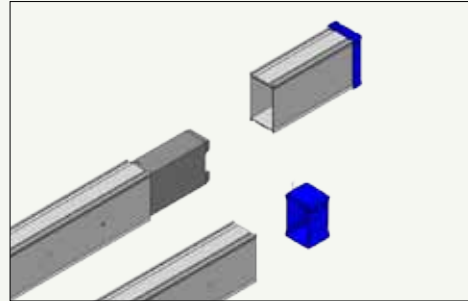
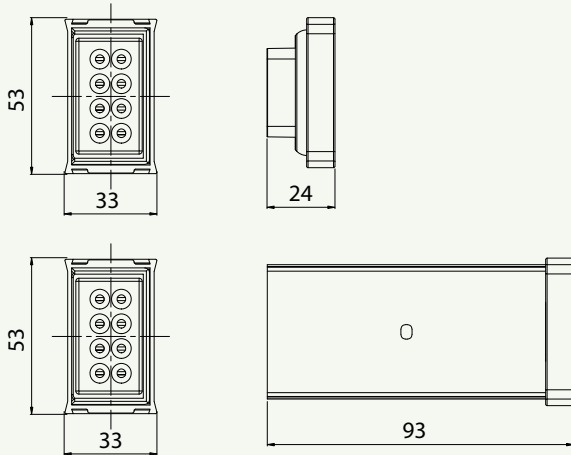

Capacity	Source/Load	Cat No.
A	Source / Load	No.
25	Source	LSLT ES
25	Load	LSLT EL
40	Source	LSLT ES
40	Load	LSLT EL
63	Source	LSLT ES
63	Load	LSLT EL

Hanger

General Type

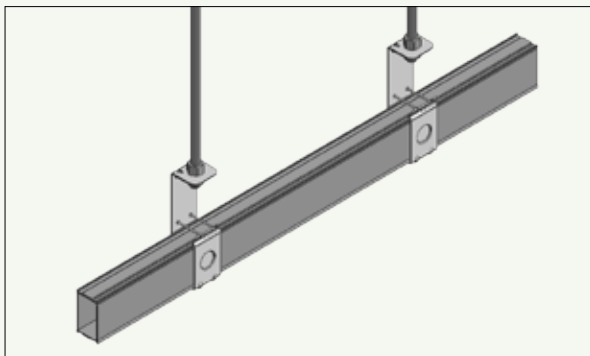

Product	Install Method	Maximum Load
		kg
General Type	It is installed at the hanging bolt.	60
Direct Type	It is installed at the fixing band.	60

Direct Type

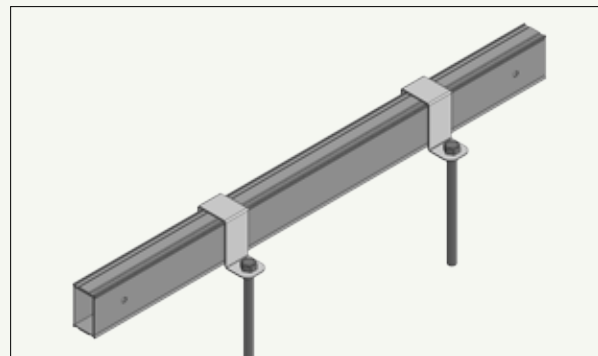

- The hangers are used to install the busducts at buildings.
- They can be either installed directly to the ceiling, or at the hanger rods.
- The standard installation interval between hangers is 1.5 meters. (Caution) When the hangers are used to fix lamps, avoid the positions of the joint connection.

? Note

Please contact our design team if a special type of hangers (Tee or Reducer) are required due to the installation environment.

Plug-in Unit

The load distribution system can be either installed or removed with a live line. The unit is a double-sided clamp to connect a conductor, and incombustible materials have been used for the insulation and plastic

Phase Joint Type

It is usually used for single phase products, and the design maximizes the convenience.

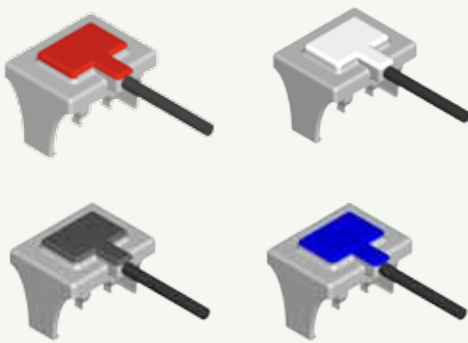

Phase Selection Type

The adaptability of this type provides options to select a suitable phase depending on the condition of the installation site. The internal process can be checked through the transparent cover.

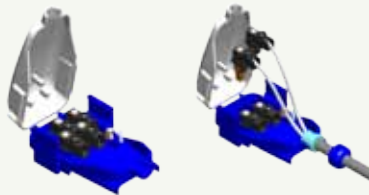

Product	Capacity(A)	Phase	Cat No. (No)
Phase Joint Type	10/16A	L1+N	LSLT P10F1
		L2+N	LSLT P10F2
		L3+N	LSLT P10F3
Phase Selection Type	10/16A	L1+N	LSLT P10S1
		L2+N	LSLT P10S2
		L3+N	LSLT P10S3
		L1+L2	LSLT P10S12
		L1+L3	LSLT P10S13
		L2+L3	LSLT P10S23
		L1+L2+L3+N	LSLT P10S4
Fuse Type	10/16A	L1+N	LSLT P10FU1
		L2+N	LSLT P10FU2
		L3+N	LSLT P10FU3
		L1+L2	LSLT P10FU12
		L1+L3	LSLT P10FU13
		L2+L3	LSLT P10FU23
		L1+L2+L3+N	LSLT P10FU4

Fuse Type

It is the same type as the phase selection type; however, the fuse type comes with a fuse for each phase to protect faulty current and overcurrent caused by load distribution.



Plug-in Type

It is designed for low capacity products (63A or less). Easy to use and a 1-outlet or 3-outlet plug-in is available.

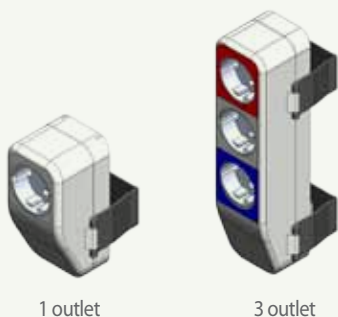

Product	Capacity(A)	Phase	Cat No. (No)
1 outlet	10/16	L1+N	LSLT P10S1
		L2+N	LSLT P10S2
		L3+N	LSLT P10S3
		L1+L2	LSLT P10S12
		L1+L3	LSLT P10S13
		L2+L3	LSLT P10S23
		L1+L2+L3+N	LSLT P10S4
3 outlet	10/16	L1+N	LSLT P10FU1
		L2+N	LSLT P10FU2
		L3+N	LSLT P10FU3
		L1+L2	LSLT P10FU12
		L1+L3	LSLT P10FU13
		L2+L3	LSLT P10FU23
		L1+L2+L3+N	LSLT P10FU4

Technical Data

Impedance and Voltage Drop

The formula to measure the voltage drop of a Busduct is shown below. The impedance and voltage drop values for aluminum and copper conductors are shown in the table below.

The values listed are measured between the upper and middle lines at 60Hz. For a 50Hz installation, multiply the reactance (X) by 0.83.

$$V_d = I \times \sqrt{3}(R \cos\theta + X \sin\theta)$$

V_d = voltage drop[V] · I = rated road amperes[A] · R = resistance[Ω] · X = reactance[Ω] / \cos = power factor / \sin = reactive factor

$$\text{Actual voltage Drop} = \alpha \times V_d \times \frac{\text{Actual load current}}{\text{Rated load current}} \times \frac{\text{Actual length of the line (m)}}{100\text{m}}$$

α (Load Constant) $\alpha = 1$, concentrated load
(a place such as an electrical room)

$\alpha = 0.5$, Distributed load
(a place such as a vertical section)

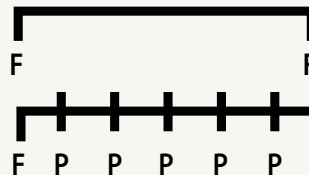

• **F** : Flanged End (panel connections)
• **P** : Plug-in Unit

Ampere(A)		10 ⁻³ Ω /100m, 60Hz			Voltage Drop(V/100m)			
		R	X	Z	0.7	0.8	0.9	1
CU	25	8.1	0.2	8.1	0.25	0.29	0.32	0.35
	40	3.35	0.167	3.4	0.17	0.19	0.21	0.23
	63	1.67	0.141	1.7	0.14	0.16	0.17	0.18

Short Circuit Strength

LT-way has been tested under actual short circuit conditions according to IEC 61439-1 and 6 [(previous standard) IEC 60439-1 and 2].

Ampere(A)	Copper(kA)	
	1 sec.	3 sec.
25	0.6	0.34
40	1.4	0.8
63	1.4	0.8

Temperature rise

The temperature rise limit is an important property which determines the performance of busducts. The temperature rise limit of the Busduct is designed so that when a Busduct is operated with a rated current, the temperature limit values of the housing are within 55K as specified in IEC61439-1 and 6 [(previous standard) IEC 60439-1 and 2].

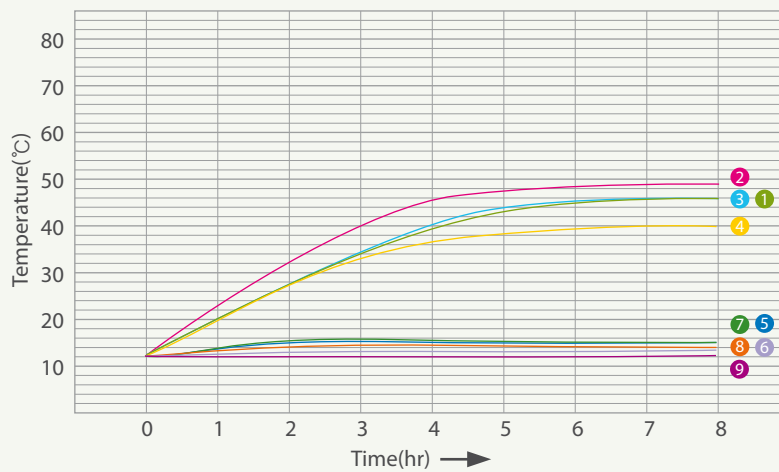
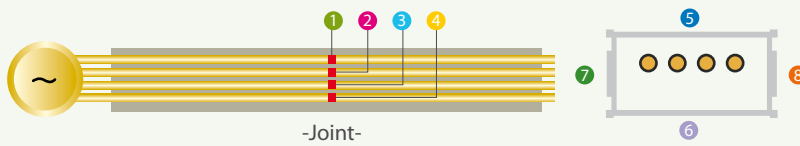

Classification	1	2	3	4	5	6	7	8	9
Censer Location	Connection Conductor				Housing				Ambient Temperature
Temperature Rise Value	46K	49K	46K	40K	15K	14K	15K	14K	12°C

Joint Connection

1) Check the condition of the joint, and loosen the cross heads of the protection cover.

2) Insert the end into the other as shown in the image below, and tighten the cross heads.

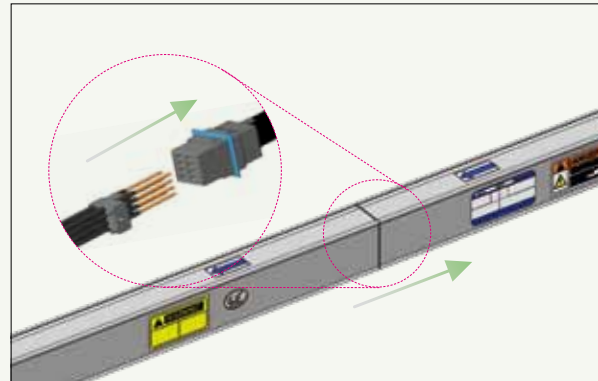
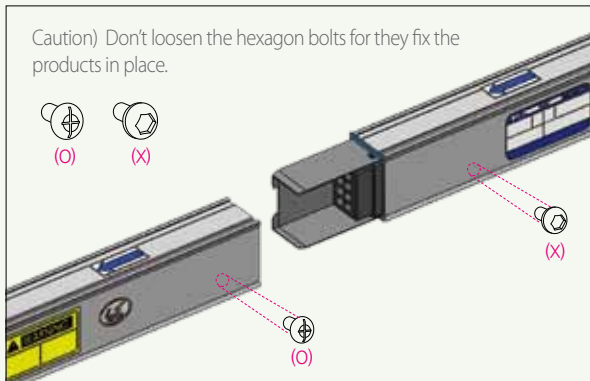

! Caution

Make sure to clean the parts of the joint before installation. Proceed with caution since the joint can be damaged by impacts. Be sure to keep them straight and steady to connect.

Plug-in Unit Installation

Open the plug cover as shown below, and insert an appropriate plug-in unit or an outlet plug.

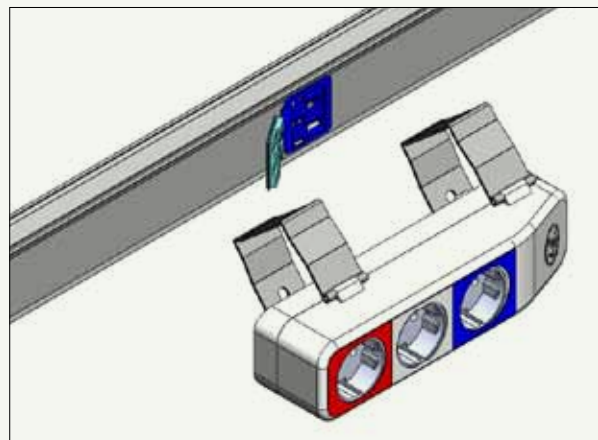
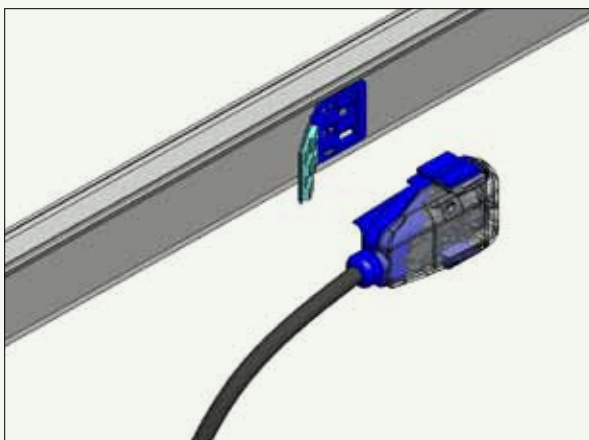

! Caution

Make sure the plug-in holes are clean before inserting the plug-in unit. Be sure to check the phase of unit and the plug.

Certification & Specification



Temperature Rise Test KERI Certification



Temperature Rise Test KERI Certification



Heat Resistant Performance Certification



TUV Environmentally Friendly Certification



ISO 14001



ISO 9001



OHSAS 18001

Global Network

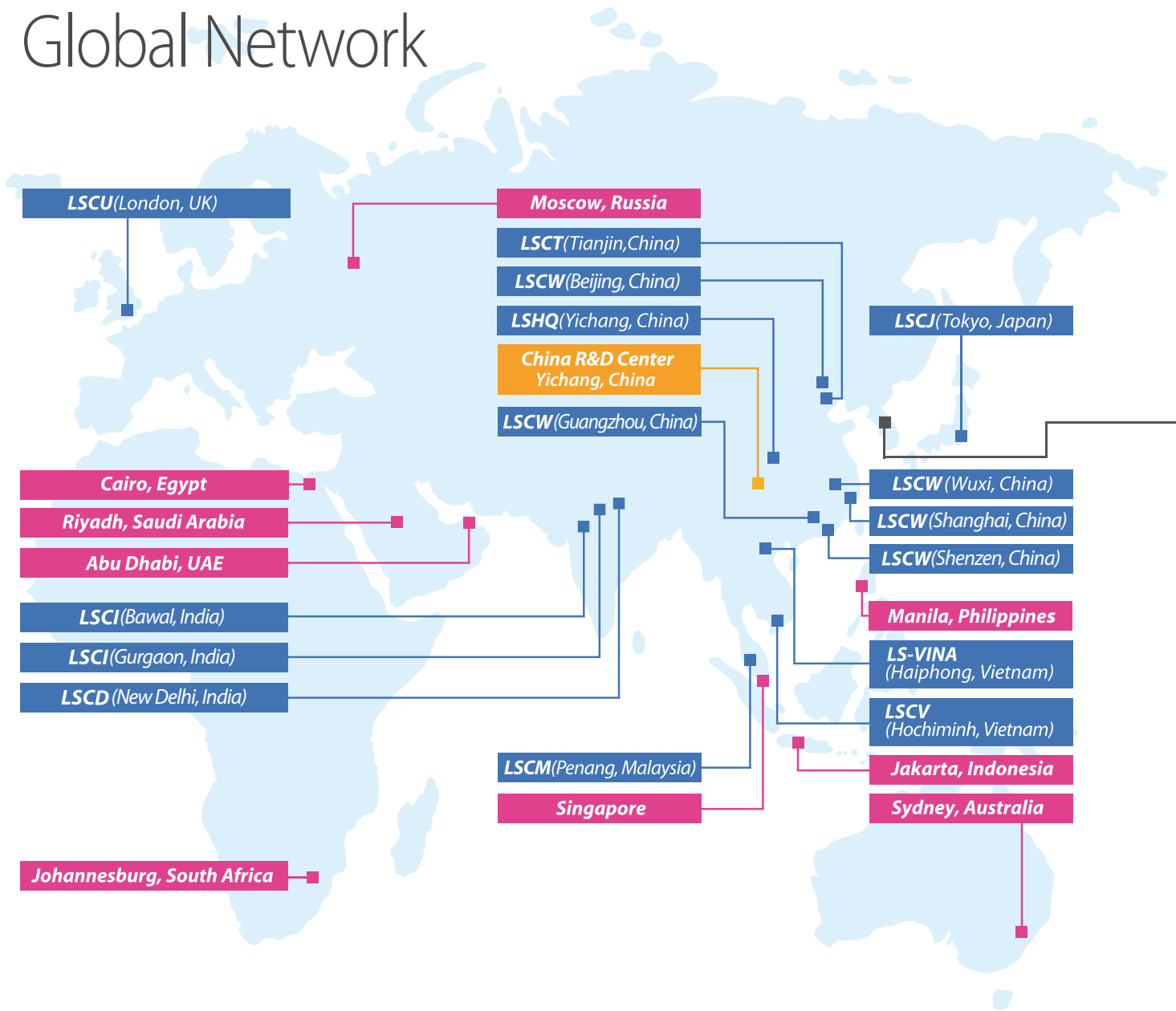

Branches

Abu Dhabi Office(U.A.E.)

Tel. : +971-2-674-8780 Fax : +971-2-674-8781

Riyadh Office(Saudi Arabia)

Tel. : +966-11-269-4911

Singapore Office(Singapore)

Tel. +65-6342-9162-3 Fax : +65-6342-9165

Sydney Office(Australia)

Tel. +61-2-9460-0255 Fax : +61-2-9460-0355

Moscow Office(Russia)

Tel. : +7-495-258-18-05 Fax : +7-495-258-18-06

Lima Office(Peru)

Tel. : +51-1-221-9786

Johannesburg Office(South Africa)

Tel. +27-71-688-2028 Fax : +27-11-785-8327

Jakarta Office(Indonesia)

Tel. +62-21-5795-7609-10 Fax : +62-21-5795-7608

Manila Office(Philippines)

Tel. +632-547-1838 Fax : +632-955-6309

Cairo Office(Egypt)

Tel. +20-2-2753-0118 Fax : +20-2-2753-0119

Subsidiaries

LSCA(U.S.A.) : Marketing and Sales

Tel. +1-770-657-6141

LSCU(U.K.) : Marketing and Sales

Tel. +44-20-8899-6671 Fax : +44-20-8899-6673

LSCJ(Japan) : Marketing and Sales

Tel. +81-3-6205-7188 Fax : +81-3-6205-7187

LSCD(India) : Marketing and Sales

Tel. +91-11-41064242

LSHQ(China)

Tel. +86-717-667-7777 Fax : +86-717-667-7618

Production : Extra-High Voltage Cable, Medium & Low Voltage Cable, Overhead Transmission Line, Industrial Specialty Cable & System

LSCT(China)

Tel. : +86-22-2699-7618 Fax : +86-22-2699-7617

Production : Magnet Wire

LSCW(China)

Tel. : +86-510-8811-9000 Fax : +86-510-8534-5341

Production : Automotive Wire & Cable, Bus Duct, Electronic Wire & Cable, Tube, ACF, Accessories for EHV Cable System

Shanghai Sales Head Office(ShangHai)

Tel. : +86-21-5237-6633 Fax : +86-21-5237-8996



LSCA (Atlanta, USA)

Lima, Peru

- **LS Cable & System Branches**
- **LS Cable & System Subsidiaries**
- **R&D Center**

Beijing Office(Beijing)

Tel : +86-10-5761-3166 Fax : +86-10-5761-3160

Shenzhen Office(Shenzhen)

Tel. +86-755-8275-0470-1 Fax : +86-755-8275-0545

Guangzhou Office(Guangzhou)

Tel. +86-20-8767-7632 Fax : +86-20-8767-7957

LS-VINA(Vietnam)

Tel. +84-31-354-0141 Fax : +84-31-354-0142

Production : Extra-High Voltage Cable, Medium and Low Voltage Cable, ACSR, OPGW, SCR

LSCV(Vietnam)

Tel. +84-61-356-9140 Fax : +84-61-356-9148

Production : Low Voltage Cable, UTP

LSCM(Malaysia)

Tel. +60-4-588-9609 Fax : +60-4-588-9607

Production : Magent Wire

LSCI(India)

Gurgaon: Marketing & Sales

Tel. +91-124-428-5800-4 Fax : +91-124-428-5805

Bawal

Tel. +91-128-426-4267

Production : RF Feeder Cable, Network Solution, EHV, LV/MV, OPGW

China R&D Center

Tel. +86-717-667-7777

Korea Operations

Headquarters

Tel. +82-2-2189-9114

Anyang Plant

Tel. +82-31-428-4114

Production : Automotive Wire, Tube Components, HV Cable & Connectors, Bus Duct, Flooring System

Gumi Plant

Tel. +82-54-469-7114

Production : Power Cable up to 500kV, OHTL, OPGW, Data Cable, RF Feeder System, Copper Rod, Magnet Wire

Indong Plant

Tel. +82-54-469-7763

Production : Industrial Cable & Module, Optical Cable, Aluminum Materials

Donghae Plant

Tel. +82-33-820-3114

Production : Submarine Cable, Industrial Specialty Cable

R&D Center

Tel : +82-31-450-8114

Greater Value Together
LS Cable & System



LS Busduct System

136 LS-ro, Dongan-gu, Anyang-si, Gyeonggi-do, 431-831, Korea
Tel. 031-428-4147 Fax. 031-428-4281