

# BUSDUCT MINI-WAY

Environment-friendly cable for the safety of your car

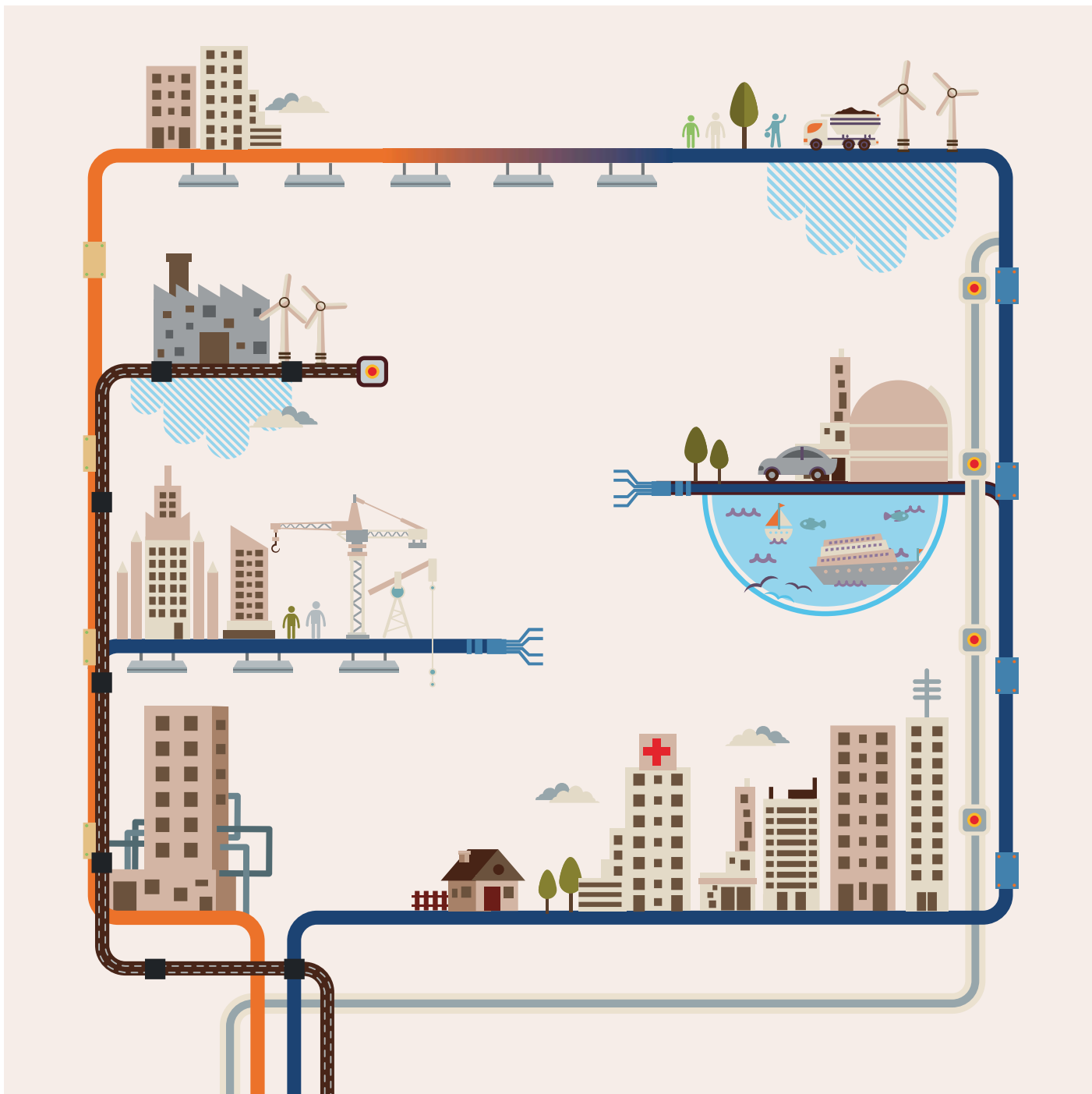

# THE WORLD BEST CABLE SOLUTION LEADER

LS Cable & System supplies various cables and materials used for power grids and communication networks around the world across all industries providing its top class technology and excellent quality. The company has also developed state of the art products, such as superconductors, HVDC and submarine cables that will lead the future energy industry.

**LS spun off from LG in 2003 as a group specializing in electronics, electrical systems, energy and materials.**



**LS** Cable & System

Transmission Cable  
Distribution Cable  
Submarine Cable  
Telecommunication Cable  
Industrial Cable  
Industrial Material

**LS**ELECTRIC

Electric &  
Automatic Equipments

**LS**-Nikko Copper

Copper Refinement

**LS** Mitron

Mechanical &  
Electronic Parts

**yesco**  
LNG

**E1**  
LPG

**GBON**  
Power &  
Communication  
Cables



# LS Cable & System Busduct System Solution



## **Buildings**

The LS C&S Busduct system is easy to install, and ensures large capacity of energy transmission while providing space efficiency which makes the bus duct system ideal for high-rise buildings, office buildings, data centers and apartment complexes.



## **Plants**

The full lineup is consisting of NSPB, CAST RESIN and SIB that can cover up to 27kv, and the lineup thus enables us to provide our clients customized designs. The system is suitable for electrical rooms and power lines, and it features a real time monitoring system using the temperature and power monitoring system.



## **Data Center**

The flexibility and expandability as well as easy maintenance property of the busduct system provides the best alternative to improve the existing problems of the conventional power cable system of data centers, which requires constant extension, reinstallation and capacity modification of loads.



## **Apartment Buildings**

Although the demands for more electricity for families are growing, the space for EPS area has reduced. Due to the change, the need for busducts and multi boxes have increased.



## **Hospitals**

The stability of the power supply in the hospitals is perhaps the most vital element, because its failure could threaten the safety of patients. The Busduct system distributes larger capacity of electric power, and provides stability of the loads which make it an ideal choice to satisfy the requirements of systematization of hospital complexes and larger hospital equipments.



## **Airports**

In order to secure the stable power supply of the airport, the busduct system provides the best customized solutions by installing high voltage busducts at the transmission, transformation and power distribution lines, and by installing low voltage busducts at the cargo, the control tower and general commercial buildings.



## **Stadiums**

The needs for a busducts system has been growing for its benefit such as large capacity of power transmission, providing a stable power supply for various loads and an eco friendly property as well as economical quality.



## **Marine & Wind**

The compact and light weight design of the busduct satisfies the demands of the clients, and comes with an outstanding quack resistance property. The busduct provides stability to the operation of the facilities through a real-time monitoring system using a temperature and power monitoring system. As the needs for renewable energy grows, the demand for our busduct has been increasing steadily.

# LS Cable & System Busduct Product Line-up

The LS Cable & System Busducts are available in a wide range of products from low current capacity LT-way (25A~63A) to large current capacity (630A~7500A), and the products enable the supply of proper capacity of power for factories and the distribution system. Our products such as the air insulated bus conducts with enhanced safety property and the cast resin busducts with resistance for high temperature, humidity and dusty environment will satisfy various application needs and provide a customized engineering service.

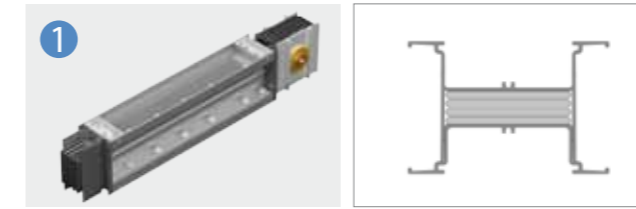
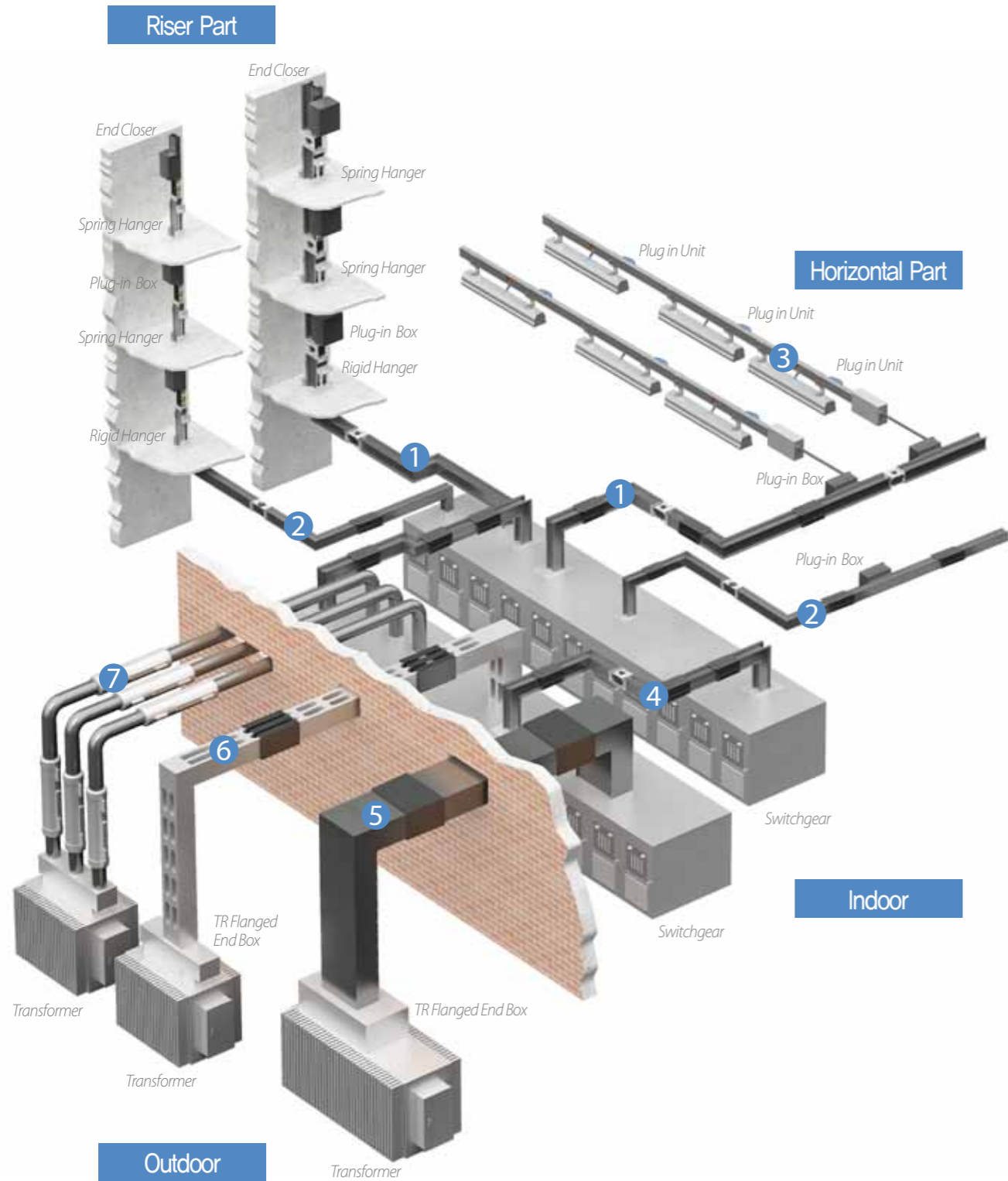

## Ez/Ex/Ef-way

Sandwich Type (PET Film, Epoxy Coating, MICA)/AL Extrusion Housing/Standard IP54/Joint Kit

- Designed for low voltage products below AC 1000V, and between 630A to 7500A.
- The most widely used conventional model.

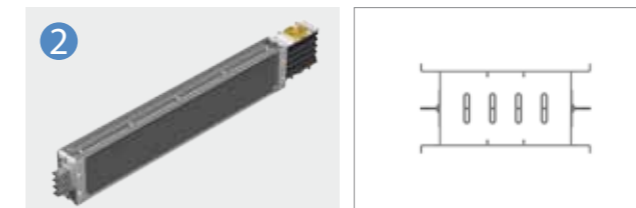

## Mini-way

Air Insulated Type/AL Extrusion Housing/Standard IP54/Joint Kit

- Designed for low voltage products below AC 1000V, and between 160A and 800A.
- Ideal for small distribution system with multi distribution loads (Vertical areas of buildings, data centers, assemble factories)



## LT-way

Flat Wire Type/Copper Conductor with PVC Extruded Insulation/AL Extrusion Housing/Various Plug Types/Joint Brush (It can be installed with a live wire.)

- Designed for low voltage products below AC 690V, and between 25A and 63A
- Suitable for Light bulbs, FFU and distribution for small equipments



## MS/Wind-way

Air Insulated Type/ Compact NSPB Type / One-Bolting Type Designed for low voltage products below AC 1000V, and between 1000A and 5000A

- A Hybrid incorporating NSPB and sandwich type
- Ideal for ships, wind towers and chemical plants where stability is required.

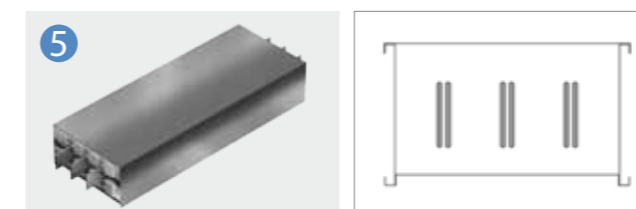

## NSPB-LV/MV

Air Insulated Type/Insulated conductors separated by phase/AL, STS and Steel Housing (optional)/Indoor Type/Outdoor Type

- NSPB-LV : Designed for low voltage products below AC 1000V, and below 4000A
- NSPB-MV: Designed for high voltage products below AC 27kV, and below 4000A
- Suitable for plants where high stability is required.

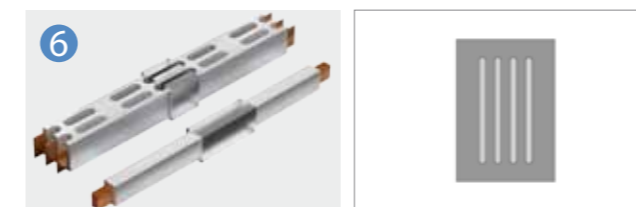

## CR-LV/MV

- Cast Resin Type/IP 68/Epoxy Molding between Conductors
- CR-LV: Designed for low voltage products below AC 1000V, and between 630A and 7500A.
- CR-MV: Designed for high voltage products below AC 27kV, and below 5000A.
- The most safe bus duct suitable for plants where high stability is required.

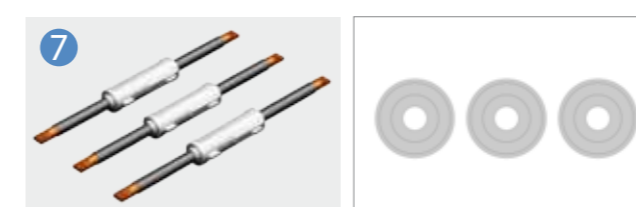

## SIB

- Epoxy Vacuum impregnated insulation Products/Suitable for phase separation system
- Designed for high voltage products below AC 27kV and below 7500A
- Small space , bending area
- Suitable for high voltage products.

# Why Busduct?

## Easy Distribution of Loads

When supplying power using cables, each load has to be connected individually to cables which waste space, and an additional distribution panel is also required. On the other hand, busducts are separated from a single line at a plug box which simplifies the electric power system. A MCCB can be installed at the plug box to effectively shut off fault current.

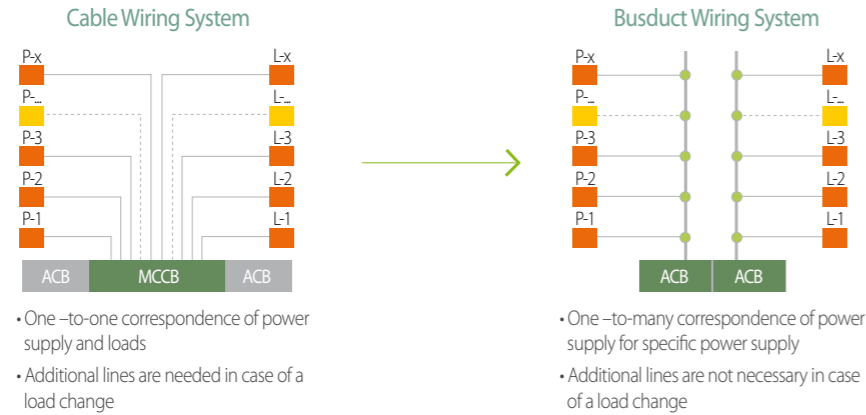

ACB: Air Circuit Breaker, MCCB: Molded Case Circuit Breaker

## Easy Installation

Pulling and cable tray installation for cables can be difficult, and requires a longer construction period, therefore increases the cost. On the other hand, the busducts use a simple installation method to connect specific length of products, which requires a shorter installation period, and is economically friendly.

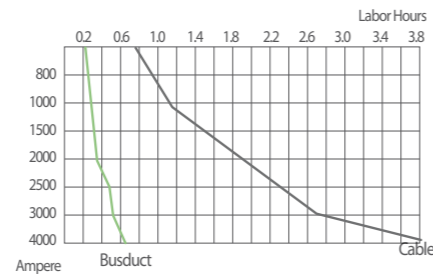

## Compact

The compact design of the busduct system provides high space efficiency at up to 50% compared to the cables. While cables require larger space to install multi lines as well as additional space for coiling areas, the busducts use proper fittings to maximize space efficiency.

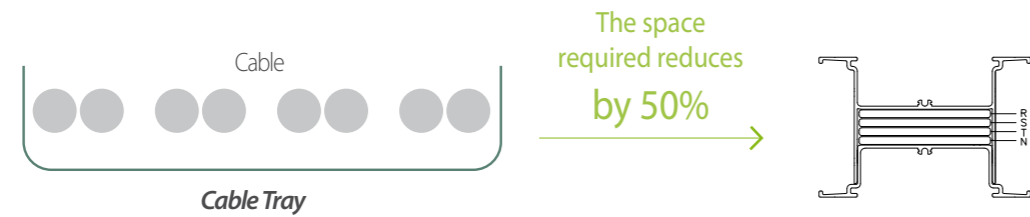

## Adaptability to various installation environment with convenience

The busduct system is a power distribution system and can be applied to various complex routes. The busduct system comes with various fittings such as elbow, off-set and tee, and can transmit high capacity currents without electrical and mechanical loss.

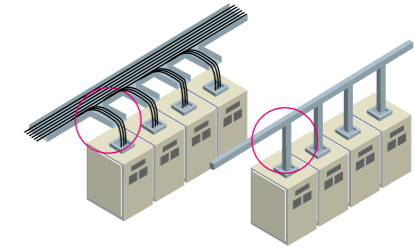

## Excellent short circuit strength

The busduct system has a high tolerance for short circuit. Its stability and reliability make it perfect for a high capacity energy transmission system.

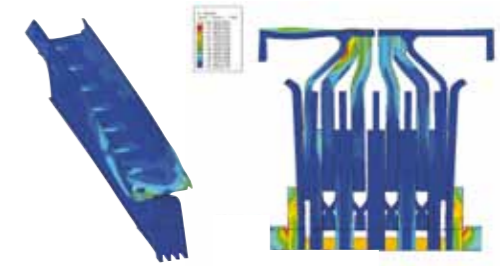

## High current density

Cables are connected directly to electric loads using racks. Its maximum allowable current ampacity limit is 1000A, and requires additional lines for a higher current. Each line of the busduct system can transmit up to 7500A, and provides high current density.

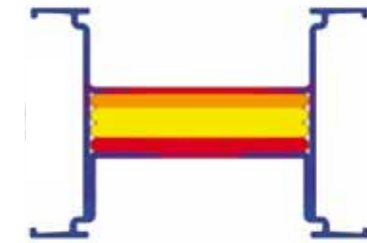

## Easy maintenance

The design of the busduct system makes it easy to detect abnormalities during installations, and ensures easy maintenance. When humidity or dust causes a malfunction on the system, the easy-to-maintain design allows replacing only the damaged part.

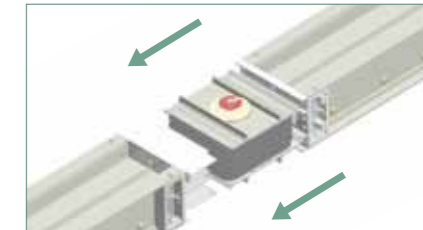

## Outstanding features of EMC and EMI

Unlike cables, the busduct system does not require a shield, instead Busduct, the housing itself performs as a shield which enhances the features of EMC and EMI.



# Why LS Cable & System Busduct

## Global Top Tier

LS Cable & System has been a long-time leading Busduct provider in Korea. With extensive experience and product line competitiveness, the company provides total solutions for each application to satisfy the needs of its clients. Using its expertise in the electronic markets of large LCD monitors and semiconductors in Korea, the company has obtained PJT sales records in 50 countries worldwide in Asia, the Middle East, CIS, and America.

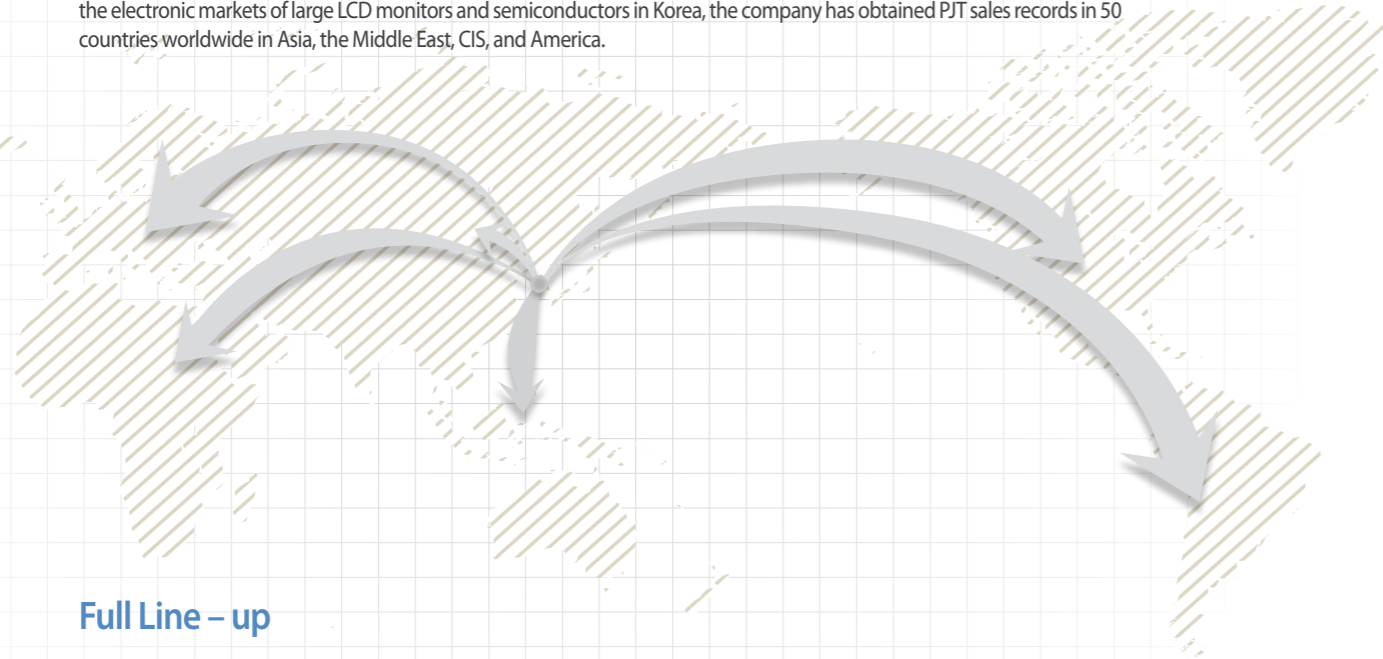

## Full Line – up

LS Cable & System is the only global company that provides a full line-up of busducts, from low to high voltage and from low to high capacity, to satisfy every need of its clients and provide an optimized solution for each PJT.



## Total Solution

- Once PJT launches, our engineer will participate to guide the clients from the initial period in order to produce the best system for our clients, and to respond quickly when the system is changed.
- Our engineers from each department provide full support in design, production, installation and testing at in-bound to satisfy our clients.
- We operate the CS Team, a task force for the busduct system, to make sure efficient after-sale service and maintenance service.

## Process

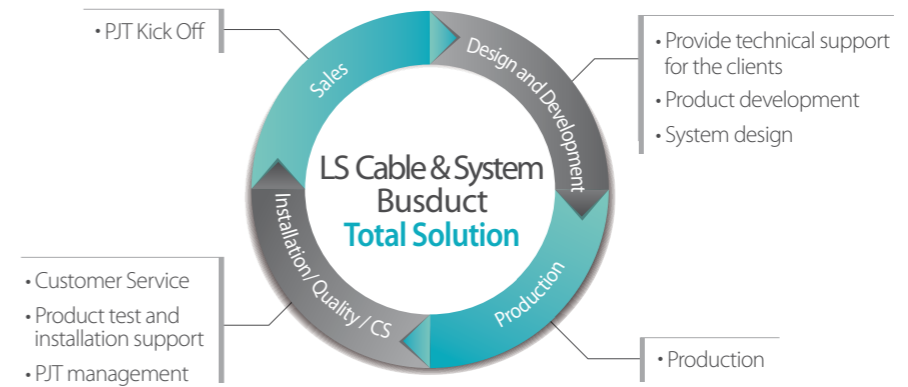

## Technical Excellence

### Unparalleled Reliability

- Provides standardized design, and owns numerous certifications such as UL Certification, Quack Proof Certification, and Impact Resistance Certification
- The CS team, a task force for the busduct system, provides efficient after-sale service
- Safe use in hazardous zones
- Manage the system using a unique temperature monitor sensor
- Semi-permanent service life
- Used qualified insulation such as epoxy and PET film for efficient insulation

### Eco friendly

- Fully recyclable
- Halogen free
- Does not contain RoHS 6 hazardous substance
- No toxicity in fire & Fire-Retardant
- Non Explosive

### Total Engineering Technology

- Provide the optimal design by experienced engineers
- Design following analysis and inspection of CAE
- Unique and exclusive design program for the busduct system
- Design based on structure stability inspection
- The excellent heat –radiating property of the aluminum housing, which ensures large capacity of power transmission
- Low Weight & Low cost
- Easy installation
- Deployable where access is difficult
- Automated epoxy insulation facility
- Unique joint kit connections
- Reduce electromagnetic
- BPMS (Busduct Power Monitoring system)
- BTMS (Busduct Temperature Monitoring system)

## The Busduct Temperature Monitoring System (BTMS : Busduct Temperature Monitoring System)

The busduct is a large capacity power distribution system. The insulation of the duct has to stay stable when the Joule lines occur during a power supply of the conductor. The rated current will be set by the insulation type and the temperature rises. These properties of the busduct make it possible to monitor and manage abnormalities of the system by checking the temperature of specific areas of the system.

The temperature monitoring system uses various temperature sensors such as optical fiber cable, IC electric chips and thermo-graphic cameras. Specific areas like the entire system line, joints, plug-in boxes and cable connection can be monitored at the central monitor room using various methods on request.

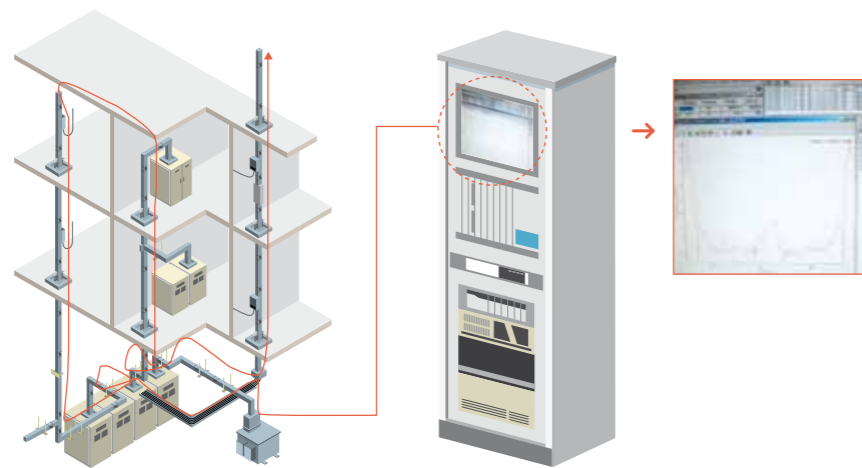

## The Busduct Power Monitoring System (BPMS : Busduct Power Monitoring System)

The ongoing trends of the busduct system are more than a simple power supplying system. The growing trend is; 1) the stability of the power system, 2) unmanned system, 3) cost cutting, and 4) green and smart grid. While the SCADA system monitors and controls the power of the main system, the BMS monitors low loads of the sub system. The frequency of the recent electrical accidents is higher at the sub system than at the main system. Therefore, the preference for the BMS system has been increasing.

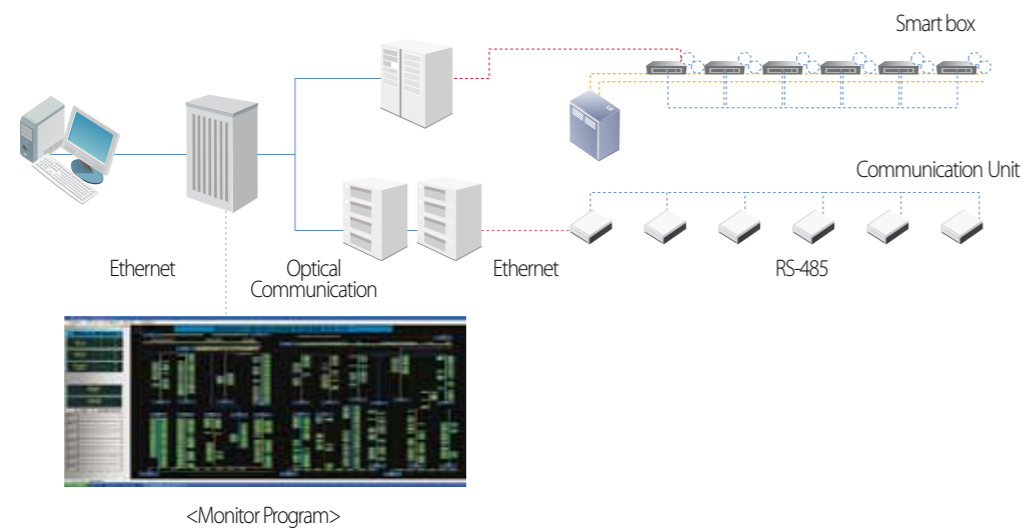

# Mini-way

LS C&S Busduct System Catalogue

02 of 08

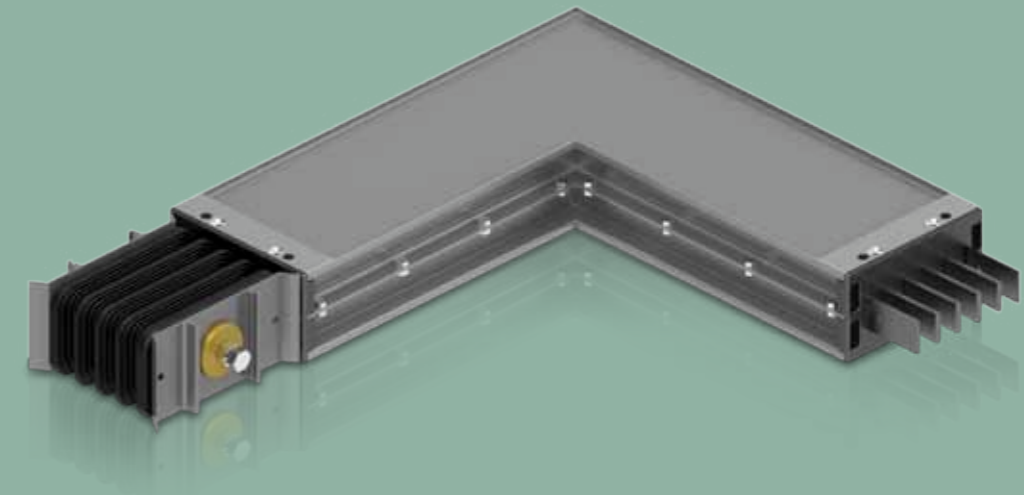

## Contents

<b>I. Introduction</b>	
- Overview	14
- Application	15
<b>II. General Data</b>	16
<b>III. Component</b>	
- Feeder	21
- Flanged End	22
- Fittings	24
- Hanger	26
- Plug-In Unit	27
- Etc	28
<b>IV. Technical Data</b>	
- Impedance	29
- Voltage Drop	29
- Temperature Rise	30
<b>V. Install Information</b>	
- Joint Connection	31
<b>VI. Certification &amp; Specification</b>	32

# Overview

## Mini-way

LSC&S Mini-way is an air insulation type bare conductor busduct, and designed for low currents at AC 1000V or less or between 160A and 800A. Each conductor is compounded with a class B rating insulating material (thermal class 130 °C) and using a joint kit system at the joint connections provides easy installation of feeders. The Mini-way comes with an IP54 rating and is water proof which reduces malfunction during operation caused by water leakage.

## Safe and Efficient Distribution System

LS C&S Mini-way is suitable for larger modern structures such as apartment complexes, factories, shopping malls, and data center server rooms because of easy load distribution, extension and installation. Our highly experienced and well-trained professionals can design highly efficient products which will harmonize with surroundings and other equipments.

## Easy Installation

The light weight of LS C&S Mini-way enables easy transportation and installation, and employing the joint kit system provides easy installation of the feeders.

## Excellent Performance

LS C&S Mini-way follows the IEC standard, and has designed the cross-section, conductor support and housing shape according to the regulations of temperature. Therefore it has efficient voltage drop and high short circuit strength.

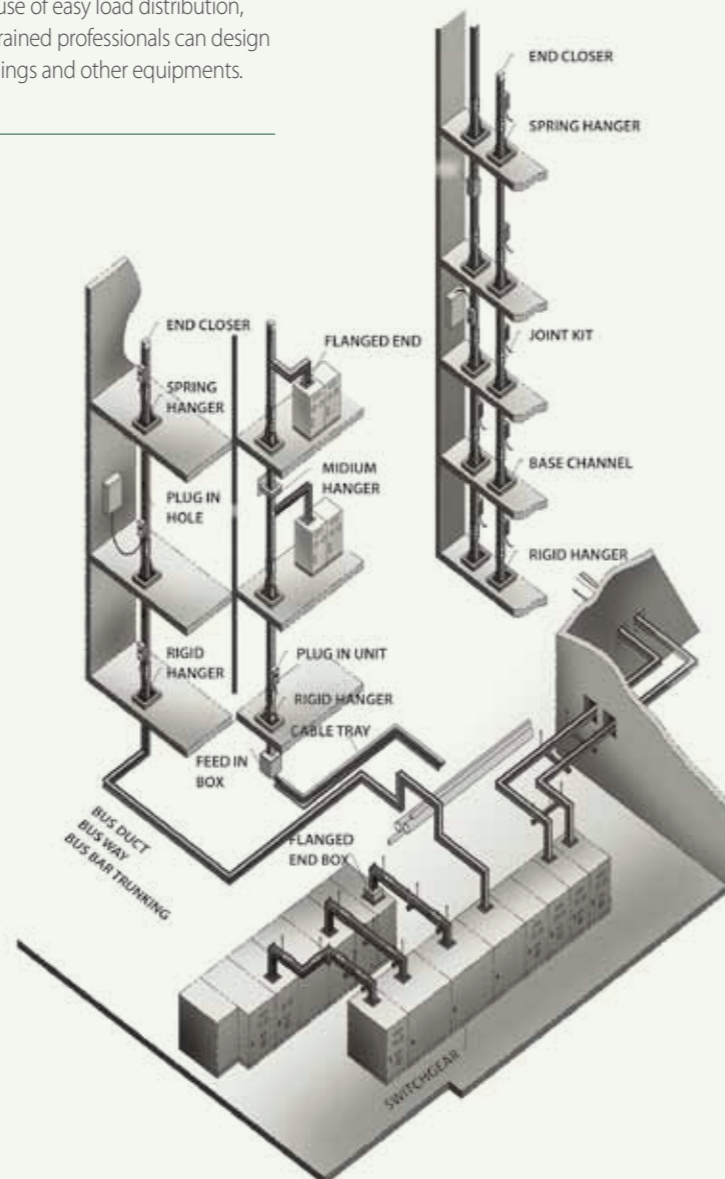

# Application

## Data Center etc.

- Supply power to computer equipments at each rack in the server room.
- Distribution boards or modular racks are not necessary.
- Consist of two lines of general use and emergency use.



## Apartments and Housing etc.

- Vertical Busducts can be installed at the EPS room.
- Provides better space efficiency than cables
- Multi-box can be applied

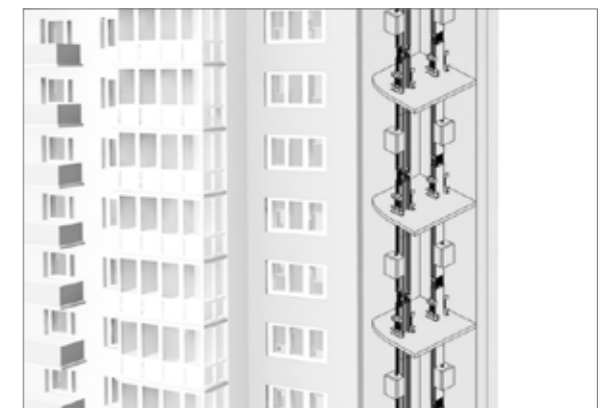

## Shopping Centers / Air Port etc

- Can be applied at the low capacity lines of department stores, supermarkets and shopping malls
- Provides better space efficiency than cables





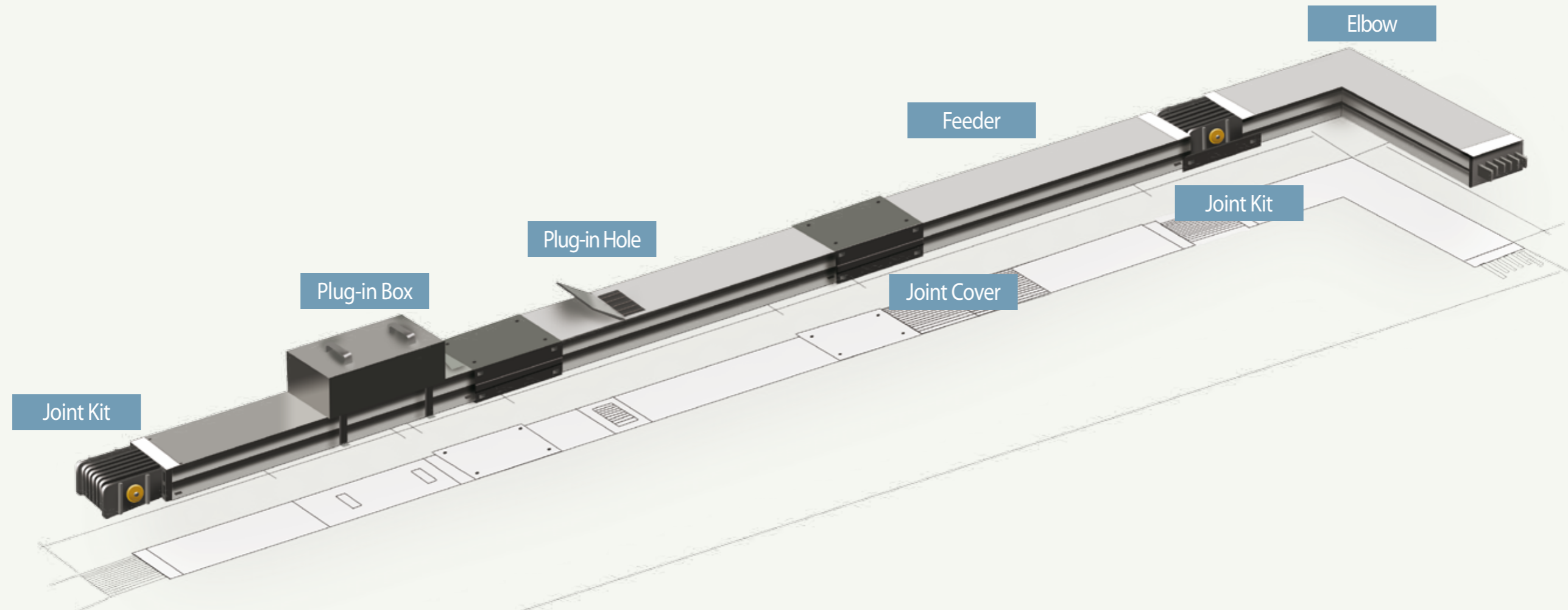

### Weight

The wonderfully light weight of the Mini-way was possible due to aluminum housing, optimizing the cross sectional areas and light weight components.



### Eco Friendly

The LS C&S Busducts acquired RoHS certification, and only uses components without hazardous substances such as lead, cadmium, mercury, chrome, PBBs and PBDEs.



### Conductors

The Mini-way uses either copper conductors with conductivity over 99%, or aluminum conductors with conductivity over 61%. The connection of the conductors is tin-plated in order to reduce contact resistance and to prevent to corrosion of the connection. (A silver plated option is available.)

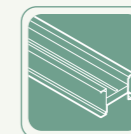

### Housing

The Mini-way uses an effective heat – radiating aluminum housing profile which produces an excellent mechanical strength and heat radiation. The aluminum housing can be used as a protective conductor (PE) due to its high level conductivity and cross sectional areas.



### Short Circuit Strength

Thanks to the optimum design of the conductor shapes, and predestinated space between support insulations, the Mini-way can withstand mechanical and thermal stress when a short circuit occurs.



### Standard

- IEC 61439-1 [(previous standard)IEC 60439-1] Power Switchgear and Controlgear Assemblies
- IEC 61439-6 [(previous standard)IEC 60439-2] Busbar Trunking Systems
- NSEN 60439 Busways
- NEMA BU 1.1 Busways



### Insulation Properties

The Mini-way uses the air insulation system. The insulation of thermal rating Class B (130°C) provides high insulation performance between conductors and between conductors and housing. In order to secure the stability of conductor support and high short circuit performance, the design is following CAE (Computer Aided Engineering) instructions.



### Joint Kit

The Mini-way uses joint kit to connect the bus ducts. In order to ensure easy maintenance and reliability, double-headed bolts and visible labels (red tags) are used to check the application, and a disc spring allows even connection of the contact surface.(Connecting torque 800~1000kgf.cm) The joint plate of the joint kit is tin plated in order to prevent discoloration and corrosion.(A silver plated option is available.)



### Permissible Operating Temperature

The cross sectional areas of the conductor and housing profile are designed to meet the standard permissible operating temperature of IEC 61439-1 and 6. Therefore the temperature rise limit of the housing is within 55K or less of the ambient temperature.



### Service Condition

- Ambient Temperature : -15 °C ~ 55 °C
- Relative Humidity : 95% or below  
(When the service condition of the environment does not meet the requirements listed above, please contact our design team.)

# General Concept

LSC&S Mini-way is an air insulation type bare conductor busduct, and it supports each phase with Class B rating insulating material (thermal class 130 °C). It is designed for AC 1000V or less or between 160A and 800A. It also comes with a joint kit system and standard IP54 rating.

## Configuration

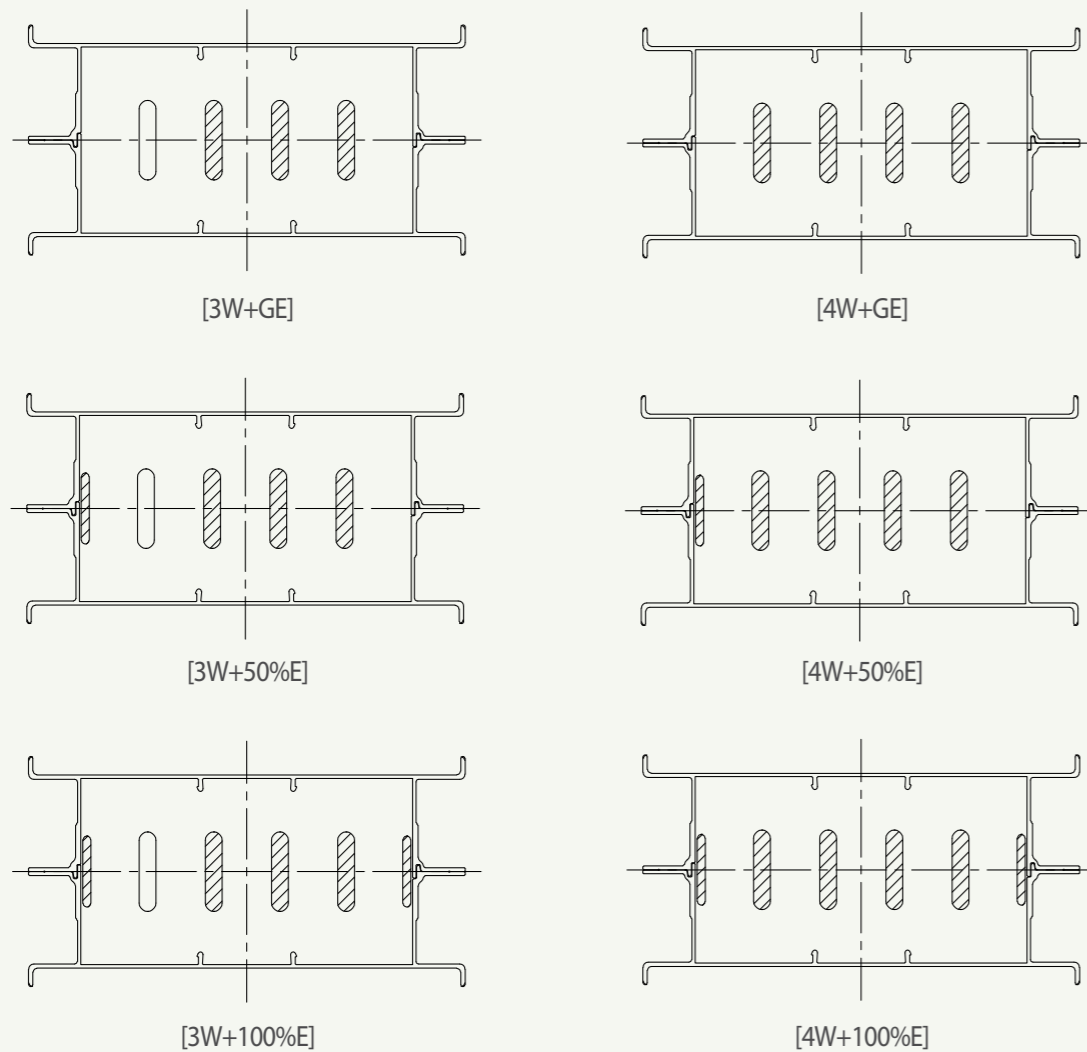

\*Special capacity such as 4W(200%N)+100%E at [Cu 160~400A] can be produced on request.

# Grounding Capacity

The aluminum housing of the Mini-way is designed to perform as a grounding conductor within the rated current. In case 50~100% more grounding capacity is needed, an internal grounding conductor can be added without changing the existing design.

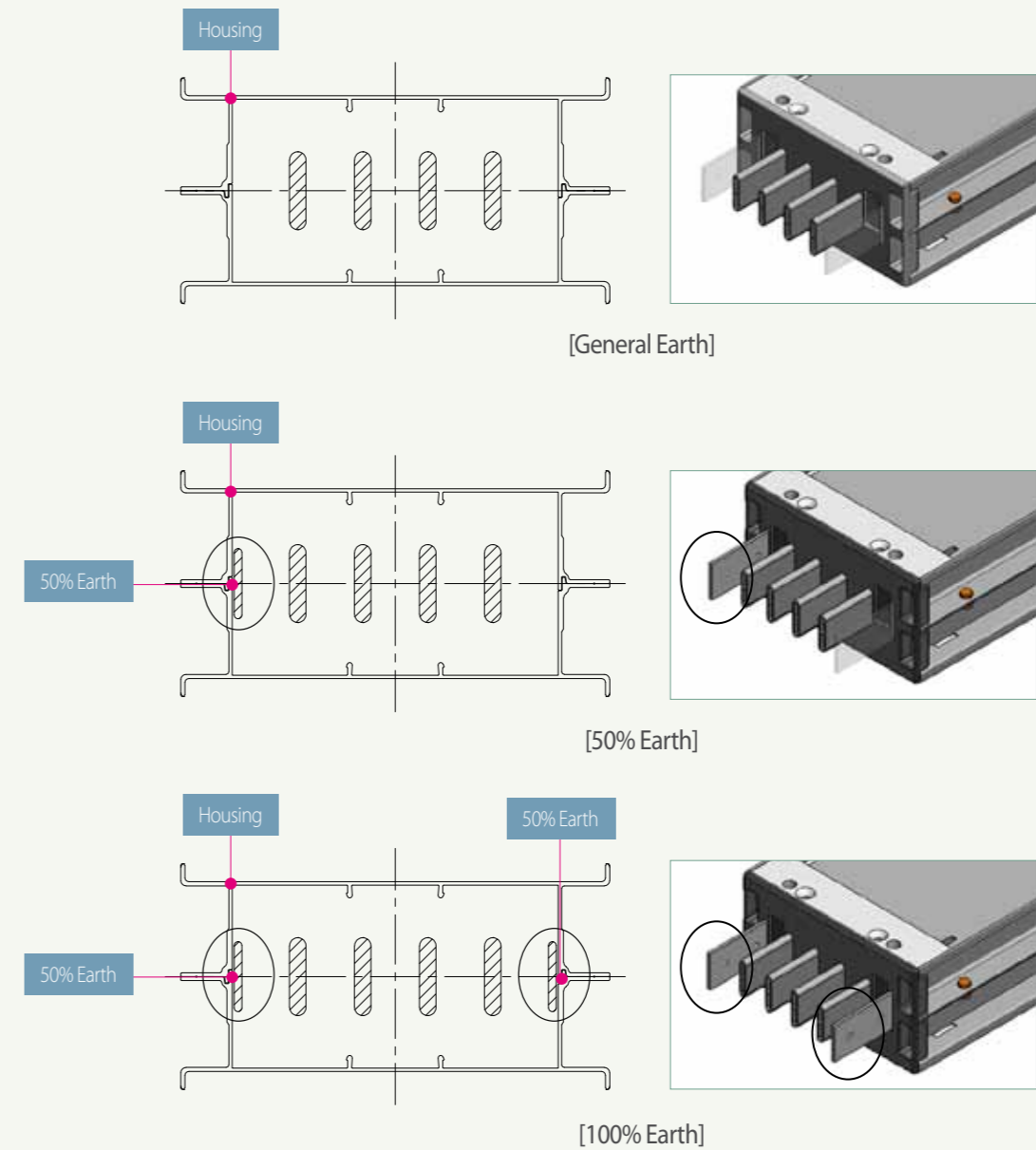

### ? Note

The aluminum housing itself acts as a grounding conductor and improves heat-radiation of conductors. The light weight of the Mini-way was possible thanks to the innovated design to reduce the weight.

# IP Code (Degree of Protection)

IP Code is an international protection degree code provided by IEC 60529(Degree of Protection Provided by Enclosure-IP Code)

NEMA STANDARD: • IP54=NEMA 12, 12K, 13 • IP55=NEMA 3, 3X, 3S, 3SX • IP66=NEMA 4.4X • IP67=NEMA 6  
 \* As the standard differs, it is a similar substitution, nota 1:1 substitution.

The degree of protection against water of the Mini-way is a standard IP54; however, it can be adjusted up to IP65. An additional sealing using high strength silicon is also available at the joint connections between the housing and the connection cover on request.

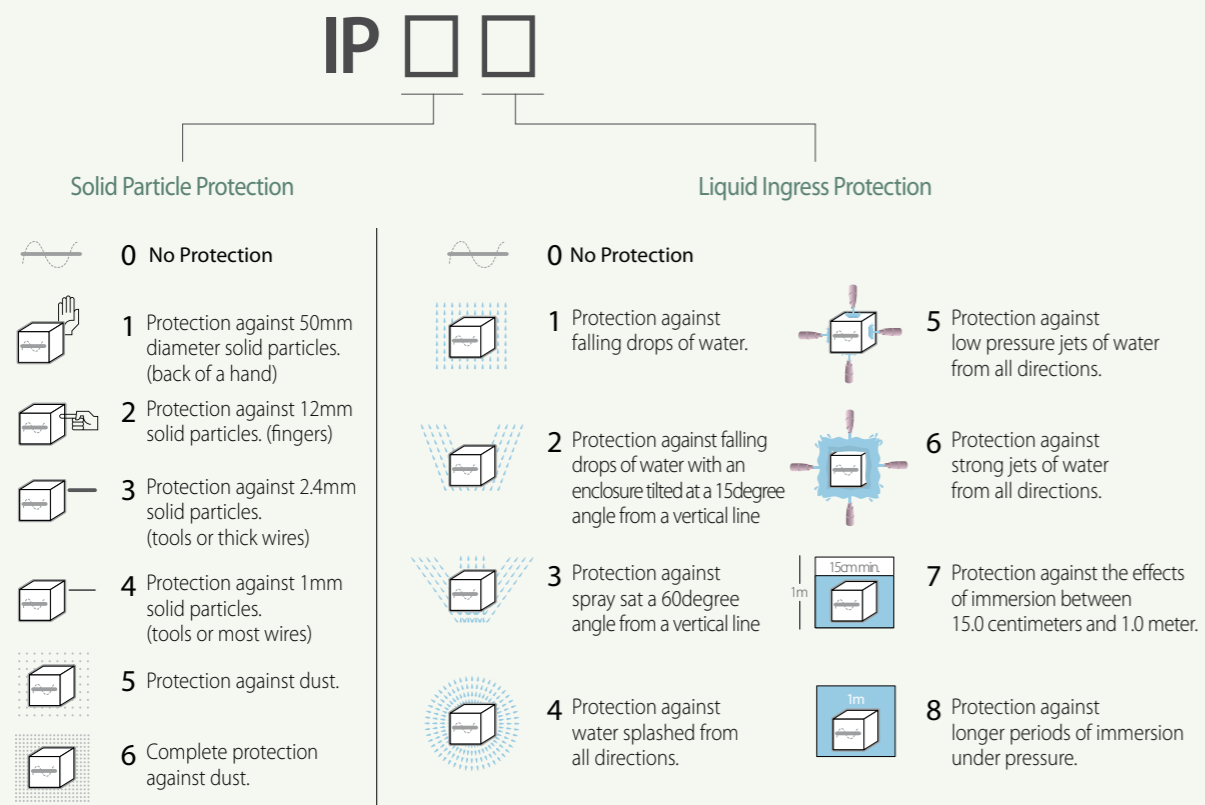

# Plating and Coating

## Plating

Standard tin plating is applied at taps, plugs and connections of conductors using an electroplating method to maintain the electrical characteristics and to prevent corrosion. Silver plating is available on request.

## Coating

In order to improve the heat radiation and to prevent corrosion, as well as to fit in with the surroundings, we apply polyester-epoxy (hybrid) power coating after treating the surface. A wide range of color is available to meet the needs of our clients.

# Feeder

Although the standard length of the Mini-way is 3 meters, it can be adjusted to the installation environment on request.

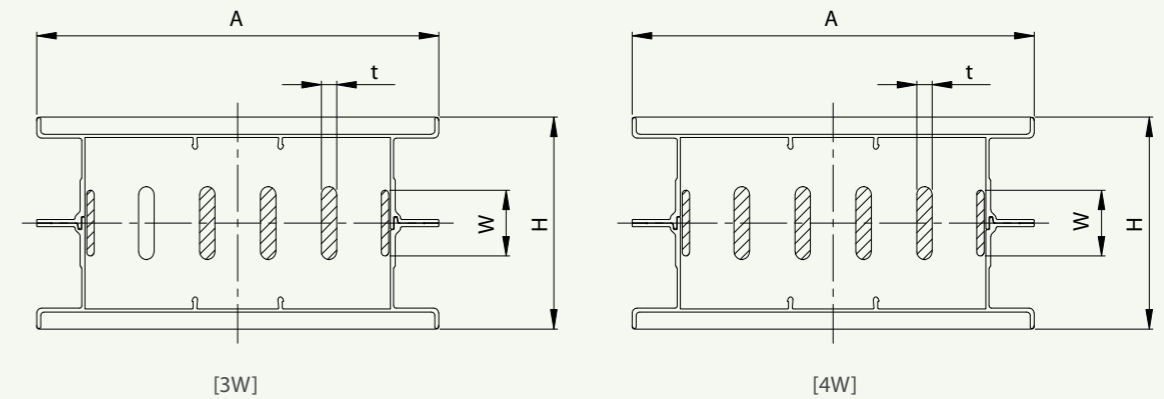
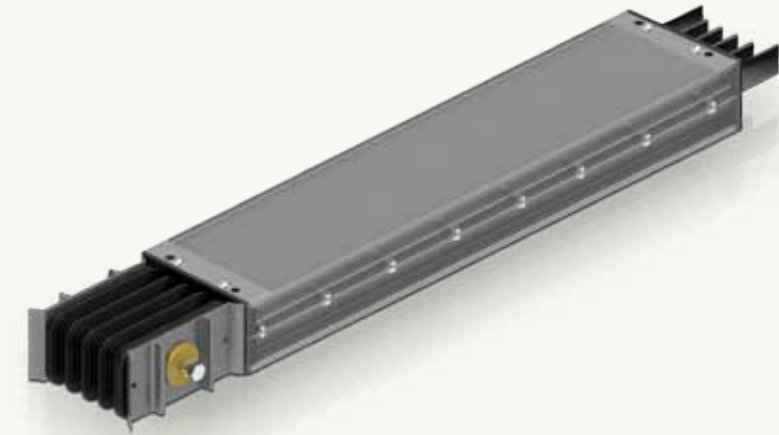

Ampere(A)	Dimension (mm)				Weight (kg/m)				
	t	W	A	H	3W	4W	4W + 50%E	4W + 100%E	
AL	160	6.35	20	165	87	5.3	5.6	5.8	5.9
	250		30		87	5.8	6.3	6.5	6.7
	400		50		107	6.9	7.7	8.1	8.4
	630		70		127	7.9	9.1	9.6	10.1
	800		95		152	9.2	10.9	11.5	12.2
CU	160	6.35	20	165	87	5.8	6.3	6.8	7.2
	250		30		87	6.8	7.6	8.3	9.1
	400		50		107	8.1	9.4	10.6	11.9
	630		50		107	12.8	15.6	16.9	18.1
	800		70		127	16.2	20.1	21.9	23.7

# Flanged End

The flanged end is connected to either a transformer or a panel.  
Dimension details are shown below.

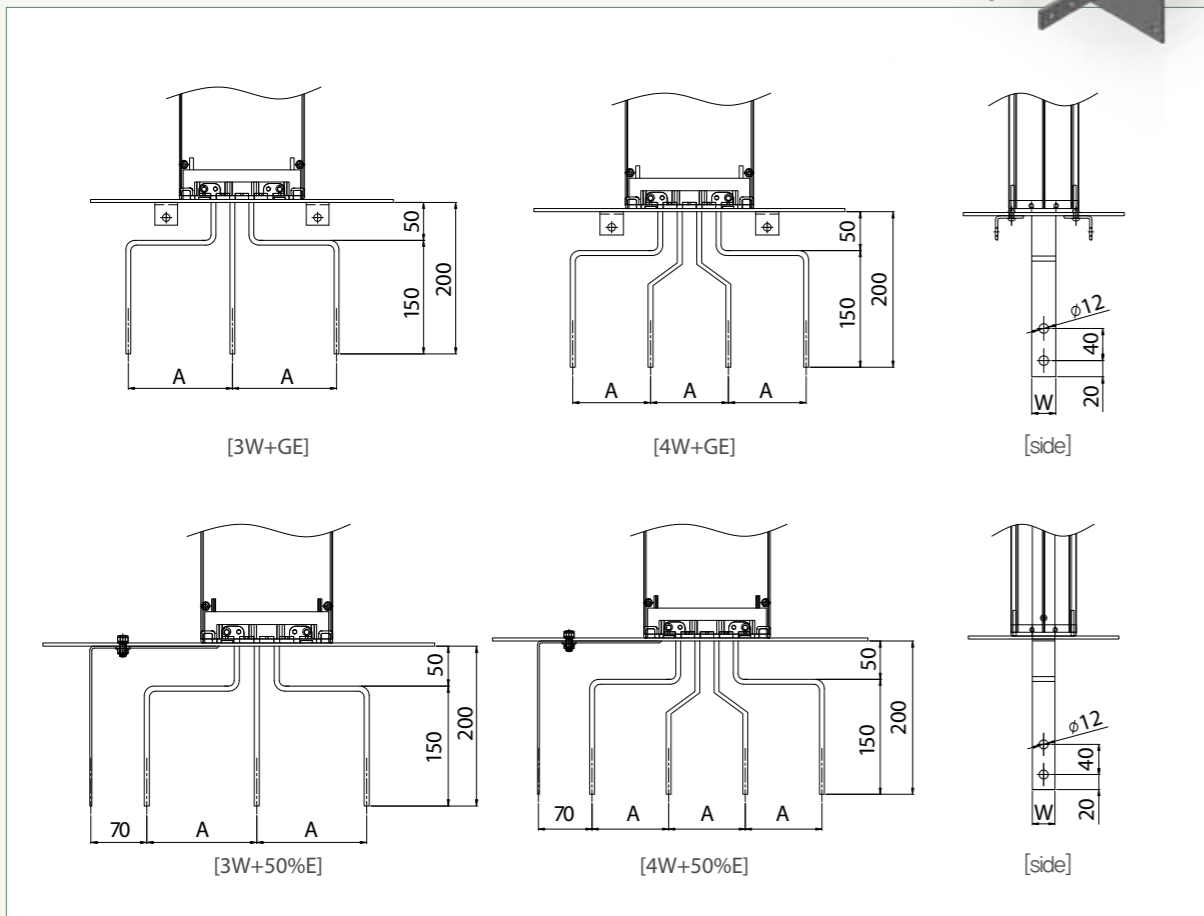
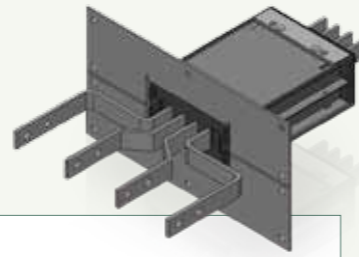

## Drilling Pattern for Flanged End

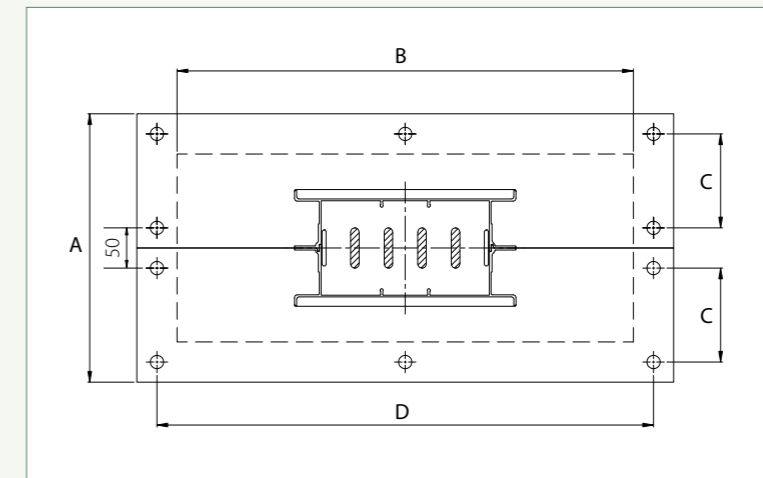

Ampere(A)	Dimension(mm)			
	A	B	C	D
AL	160	200	70	370
	250	200	70	
	400	220	80	
	630	240	100	
	800	265	125	

Ampere(A)	Dimension(mm)			
	A	B	C	D
CU	160	200	70	370
	250	200	70	
	400	220	80	
	630	220	80	
	800	240	100	

## Flanged End Box

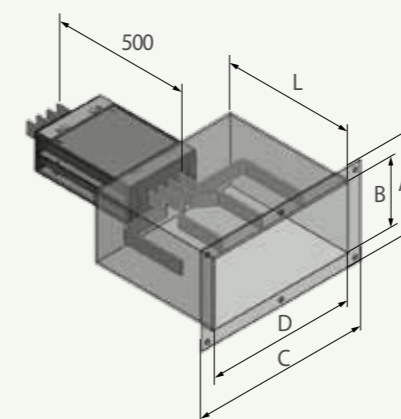

Ampere(A)	t	Dimension(mm)					
		W	A	B	C	D	L
AL	160	20	190	130	510	450	270
	250	30	200	140			
	400	50	220	160			
	630	70	240	180			
	800	95	265	205			
CU	160	20	190	130	510	450	270
	250	30	200	140			
	400	50	220	160			
	630	50	220	160			
	800	70	240	180			

Ampere(A)	t	w	Dimension(mm)	
			A	
			3W	4W
AL	160	20	100	100
	250	30		
	400	50		
	630	70		
	800	95		
CU	160	20	100	100
	250	30		
	400	50		
	630	50		
	800	70		

\*t: thickness of a conductor

# Fittings

Mini - way Busduct has a wide range of fittings to satisfy any layout of buildings. Elbow angles other than 90 °c are also available. Fitting designs are shown in the following figures, and they consist of the source-side and the load-side. Offset or combination elbows can be used where standard elbows are not feasible. (Dimensions for each fitting are shown in the following figures. Contact our design team for a minimum dimension.)

## Elbow

[Vertical]

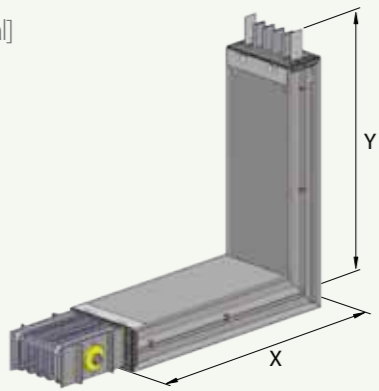

[Horizontal]

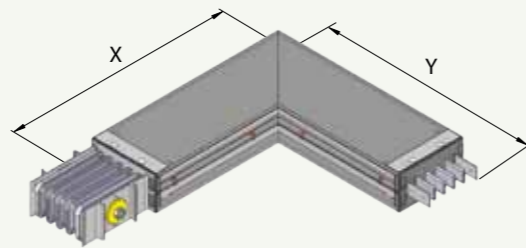

Ampere(A)	Dimension(mm)	
	X	Y
160 ~ 800	500	500

Ampere(A)	Dimension(mm)	
	X	Y
160 ~ 800	500	500

## Offset

[Vertical]

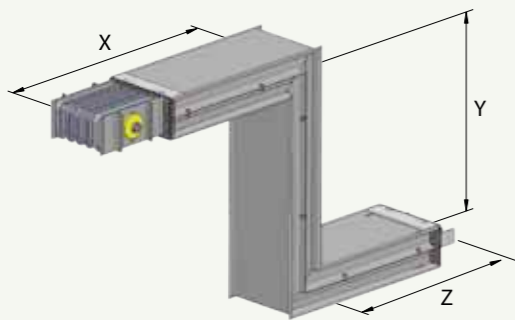

[Horizontal]

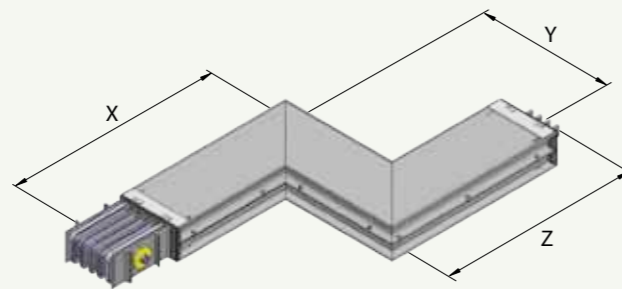

Ampere(A)	Dimension(mm)		
	X	Y	Z
160 ~ 800	500	500	500

Ampere(A)	Dimension(mm)		
	X	Y	Z
160 ~ 800	500	500	500

## Tee

[Vertical]

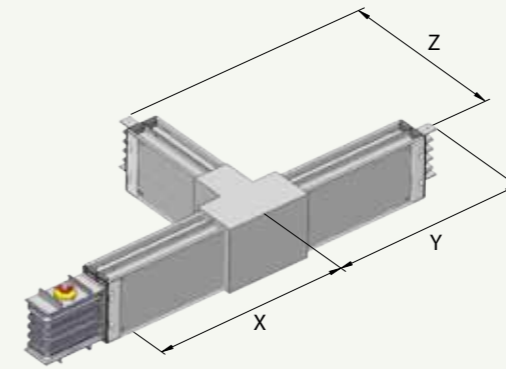

[Horizontal]

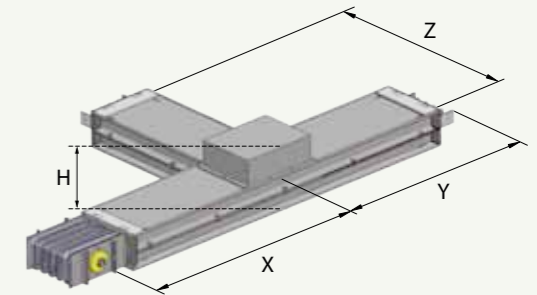

Ampere(A)	Dimension(mm)		
	X	Y	Z
160 ~ 800	500	500	500

Ampere(A)	Dimension(mm)		
	X	Y	Z
160 ~ 800	500	500	500

Ampere(A)	Dimension(mm)		
	X	Y	Z
160 ~ 800	500	500	500

Ampere(A)	Dimension(mm)	
	H_AL	H_CU
160	134	134
250	144	144
400	164	164
630	184	164
800	209	184

## Combination

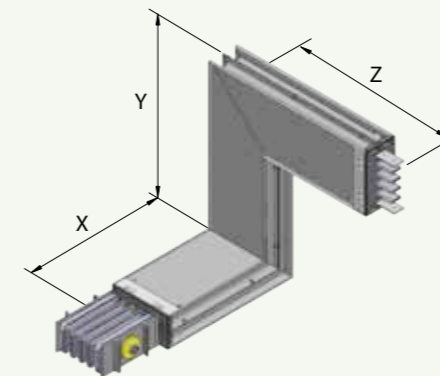

Ampere(A)	Dimension(mm)		
	X	Y	Z
160 ~ 800	500	500	500

# Hanger

Busducts installed on the ceilings, floors, walls and beams are usually supported by stud bolts, system channels, angles and channels. Various types of hangers are available depending on the installation condition or environment.  
(Please contact our design team for further information about hanger types and installation.)

## Horizontal Hangers

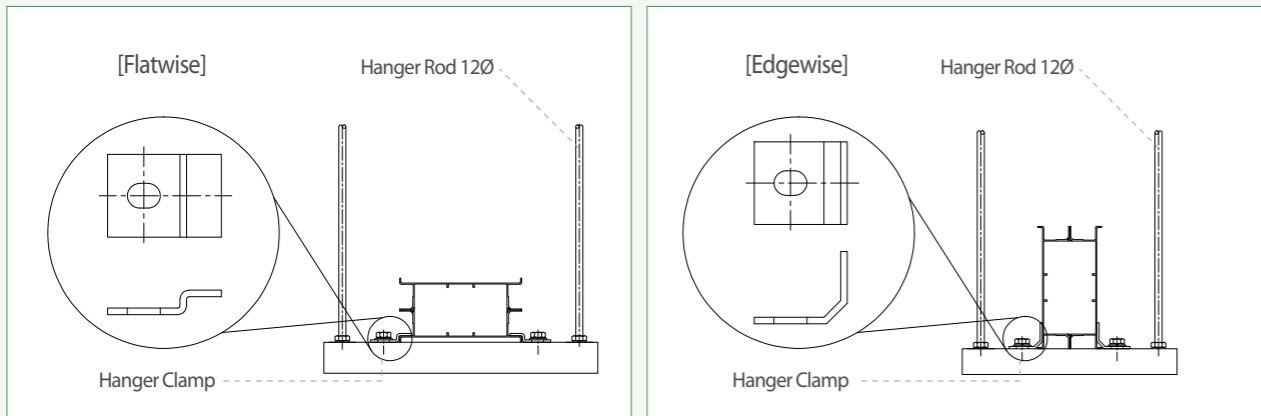

## Vertical Hangers

[Rigid Hanger]

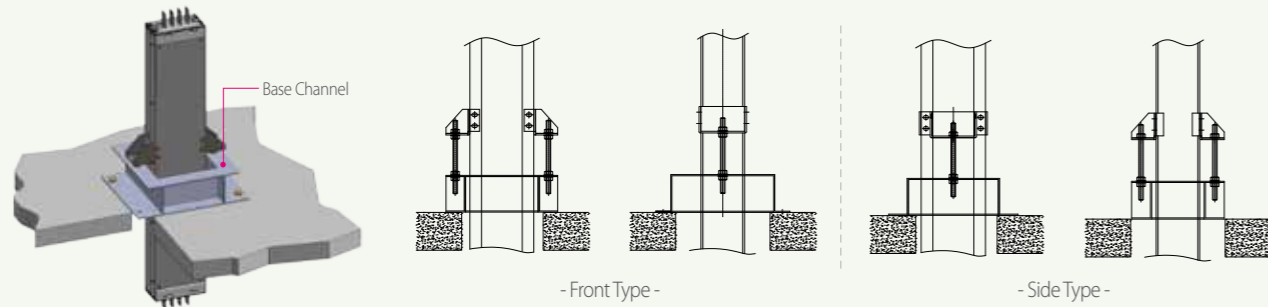

[Spring Hanger]

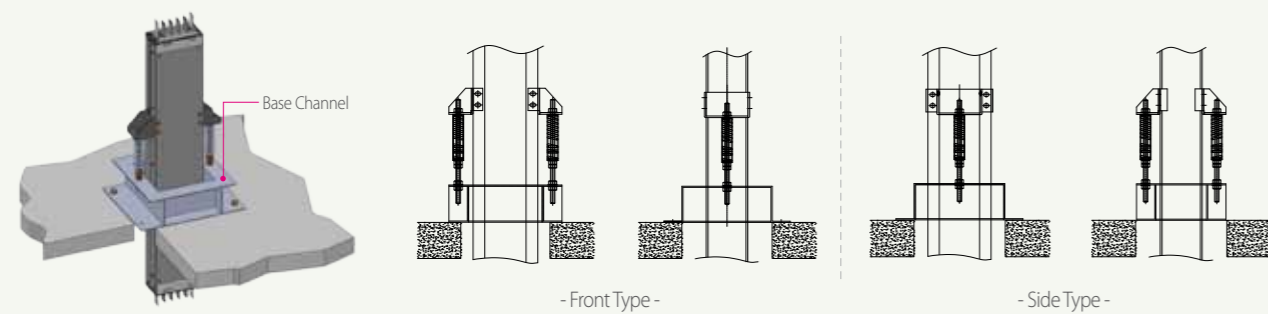

# Plug-in Unit

The position of the plug-in distribution location will be decided according to the installation environment and on request. The standard length of the feeders is 3 meters, and a maximum of 8 plug-in holes can be made on a 3 meter feeder. In order to secure the smooth access between the plug-in brushes and feeders, a guide pin has been attached to a plug-in box. The guide pin is designed to be inserted to a plug-in hole first for safe installation.

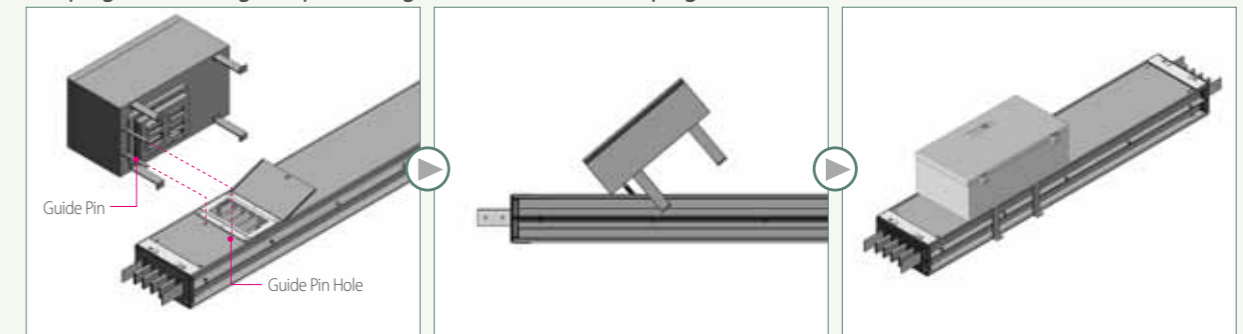

## Plug-in Box

Attachments such as CT, TD and PT can be installed in a plug-in box to control and to supervise current, voltage and wattage remotely.

## Door Types of the Plug-in Box

Various design of doors for the plug-in box is available to satisfy the demands of our clients. The available types are shown below.

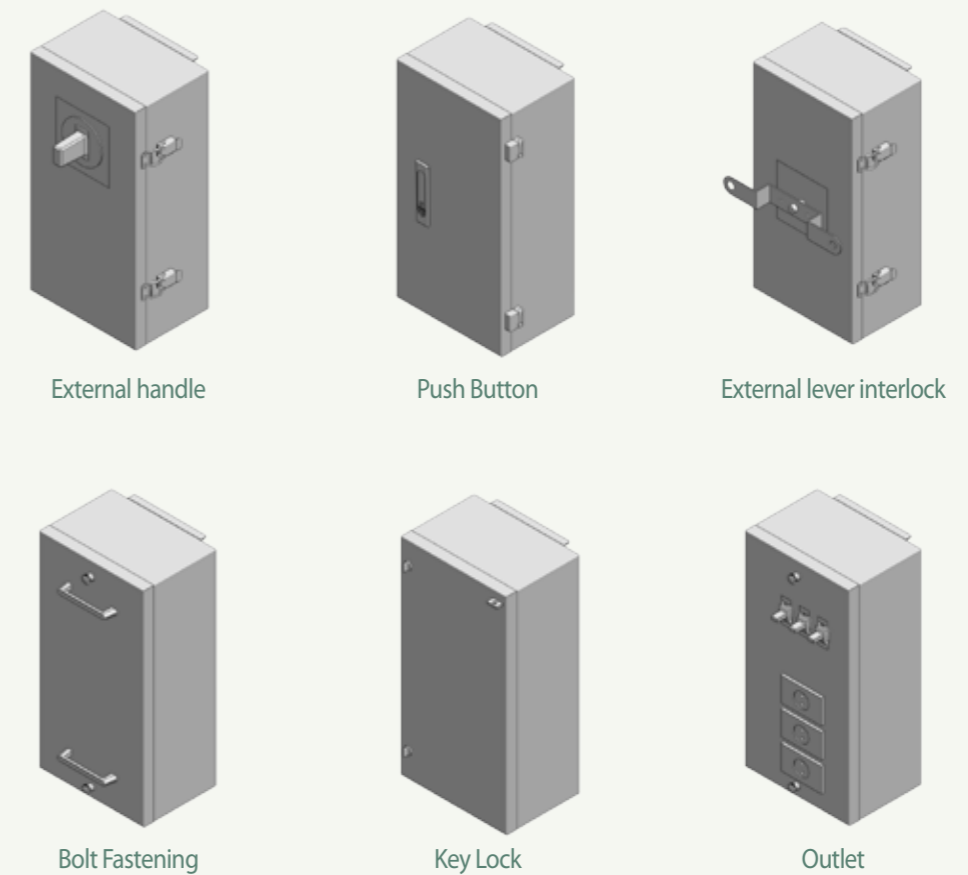

# Etc.

## Wall Flange

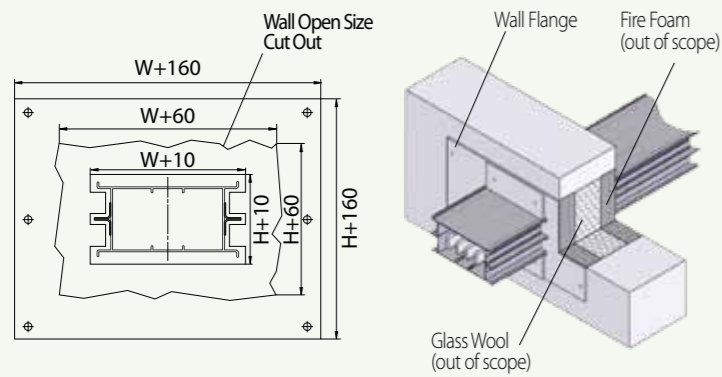

A wall flange is used to seal the gaps produced during installation of Busducts at the walls, ceilings and floors.

- W: The width of the product (165mm)
- H: The height of the product (It is decided by a rated current.)

## Floor Opening

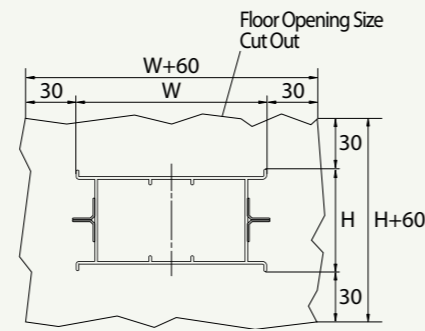

- W: The width of the product (165mm)
- H: The height of the product (It is decided by a rated current.)

## The Required Minimum Distances from a Wall for Heat Dissipation and Maintenance

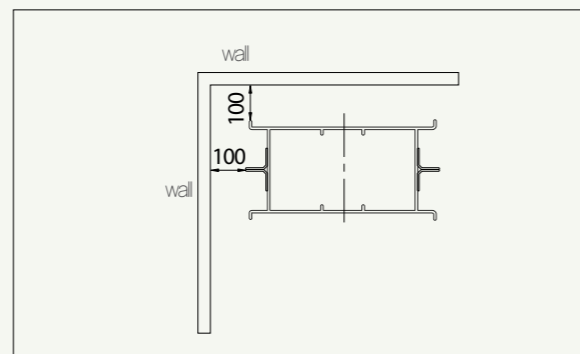
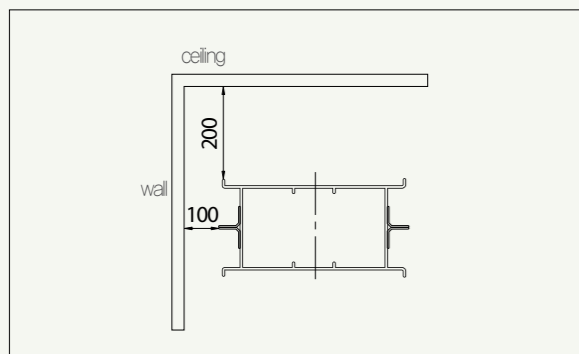
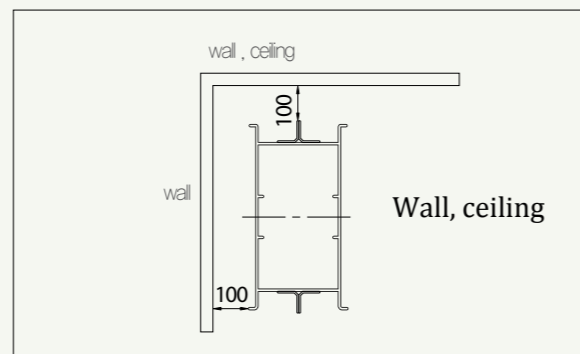
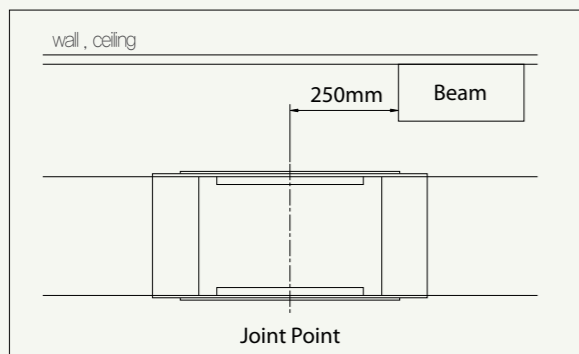

# Technical Data

## Impedance and Voltage Drop

The formula to measure the voltage drop of a Busduct is shown below. The impedance and voltage drop values for aluminum and copper conductors are shown in the table below.

The values listed are measured between the upper and middle lines at 60Hz. For a 50Hz installation, multiply the reactance (X) by 0.83.

$$V_d = I \times \sqrt{3} (R \cos\theta + X \sin\theta)$$

•  $V_d$  = voltage drop[V] ·  $I$  = rated road amperes[A] ·  $R$  = resistance[Ω] ·  $X$  = reactance[Ω] /  $\cos$  = power factor /  $\sin$  = reactive factor

$$\text{Actual voltage Drop} = \alpha \times V_d \times \frac{\text{Actual load current}}{\text{Rated load current}} \times \frac{\text{Actual length of the line (m)}}{100m}$$

- $\alpha$  (Load Constant)  $\alpha = 1$ , concentrated load (a place such as an electrical room)
- $\alpha = 0.5$ , Distributed load (a place such as a vertical section)

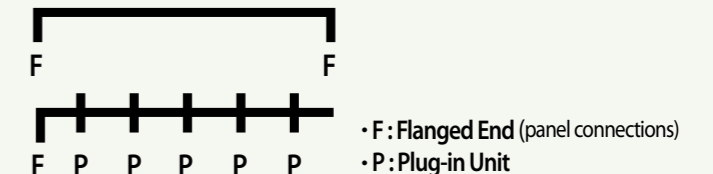

Ampere(A)	10 <sup>-3</sup> Ω / 100m, 60Hz			Voltage Drop(V/100m)				
	R	X	Z	0.7	0.8	0.9	1.0	
AL	160	66.4	18.1	68.8	8.72	9.15	9.40	8.82
	250	32	15.1	35.4	9.15	9.42	9.44	8.13
	400	15.3	13.8	20.6	10.74	10.76	10.42	8.19
	630	6.7	8.0	10.5	11.38	11.11	10.41	7.32
	800	5.0	6.5	8.2	11.28	10.95	10.16	6.92
CU	160	82.2	20.9	84.8	9.17	9.56	9.73	8.75
	250	35.1	17.6	36.3	9.64	9.80	9.68	8.04
	400	17.6	13.7	22.3	11.24	11.34	11.10	8.96
	630	5.9	9.8	11.4	12.14	11.56	10.44	6.42
	800	4.4	8.1	9.2	12.25	11.57	10.33	6.05

## Short Circuit Strength

LS C&S Busduct has been tested under actual short circuit conditions according to IEC 61439-1 and 6 [(previous standard) IEC 60439-1 and 2] at KEMA. The result and the graph are shown below. Phase to Phase Short Circuit Ratings



Ampere (A)	AL(kA)		CU(kA)	
	1 sec.	3 sec.	1 sec.	3 sec.
160	10	6	10	6
250	10	6	10	6
400	25	15	25	15
630	30	17	30	17
800	40	23	40	23

# Technical Data

## Temperature Rise

The temperature rise limit is an important property which determines the performance of Busducts. The temperature rise limit of the Busduct is designed so that when a busduct is operated with a rated current, the temperature limit values of the housing are within 55K as specified in IEC61439-1 and 6 [(previous standard) IEC 60439-1 and 2].

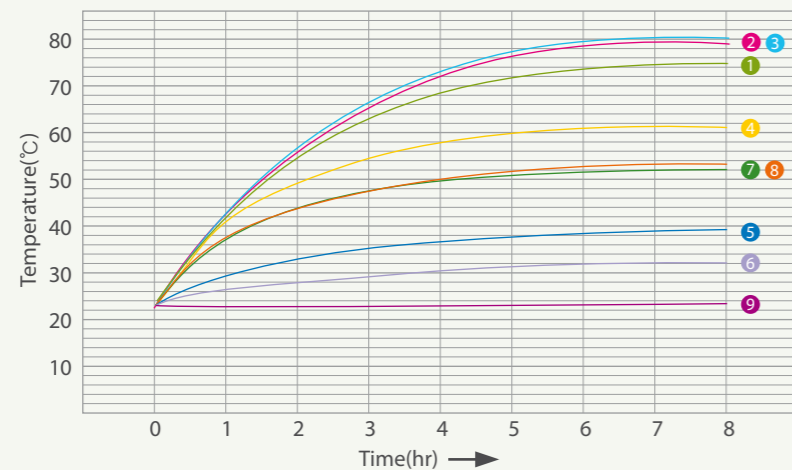
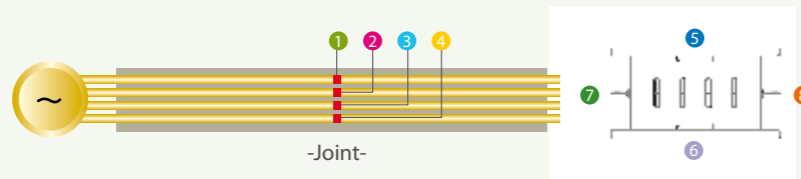

Classification	1	2	3	4	5	6	7	8	9
Censer Location	Connection Conductor				Housing				Ambient Temperature
Temperature Rise Value	75K	79K	80K	61K	39K	32K	52K	53K	23°C

# Joint Connection

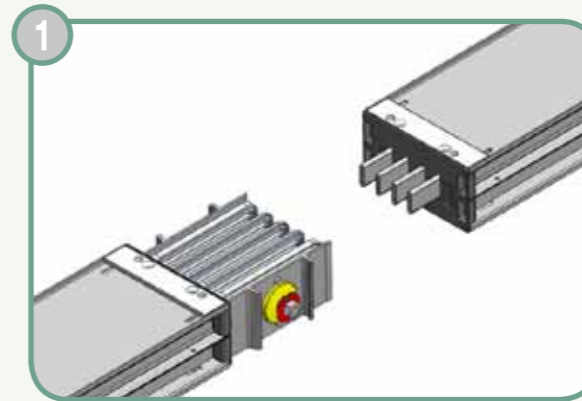

Both parts should be aligned at the top and the bottom and the left and the right as well as horizontally and vertically. (This also applies to the joint connection of the horizontal and vertical ducts.) Make sure that the joint kit is not tilted. (We recommend a jig tool for the installation.)

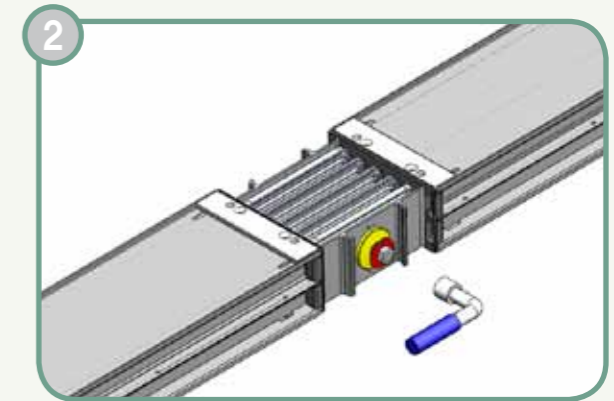

Using a torque wrench, slowly tighten the exposed bolt head of a double headed bolt. The head of the double headed bolt is designed to break off at 800~1000Kg·cm. Continue tightening the exposed head until it breaks off.

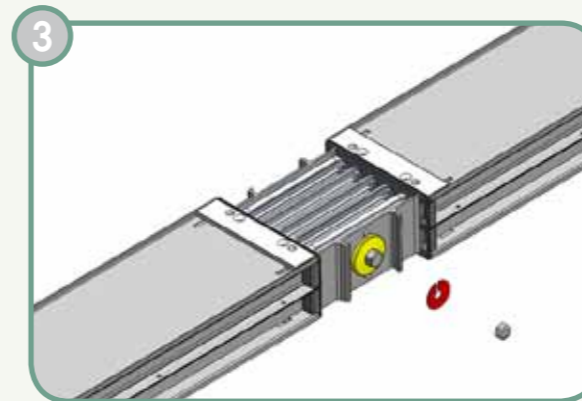

Once the exposed head and the red tag attached to it have been cut off, they are properly connected.

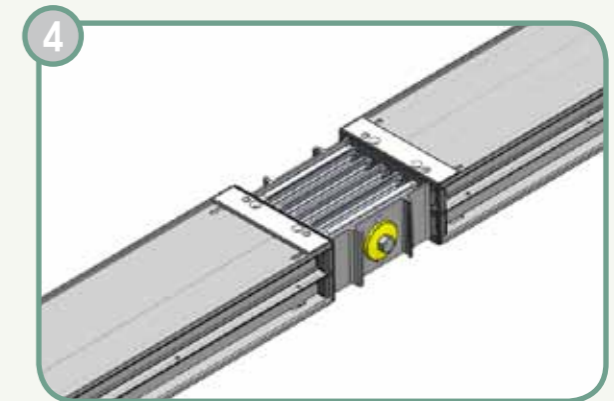

Be sure to check the distance from the housing, and the gaps between the conductors at the kit after the installation.

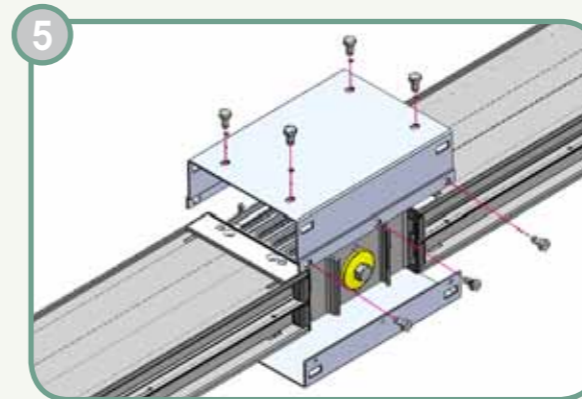

Before applying the connection cover, check the space between the end block and the holes of the connection cover.

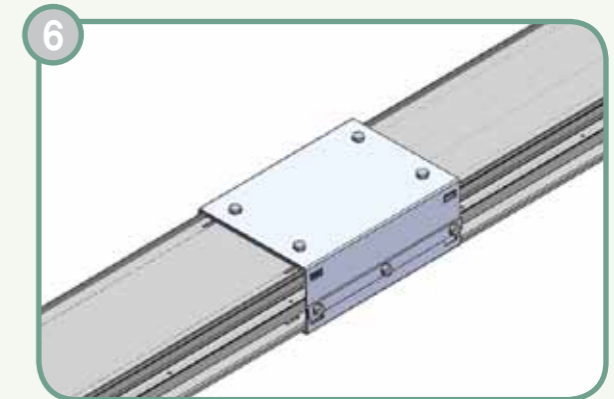

Perform the last inspection of the connection. (Follow the instruction of the installation manual for additional sealing according to the IP Code)



# Certification & Specification

# Memo



Fire proof Certification



Dust and Water proof Certification



TUV Eco Friendly Certification



KEMA Certification



KEMA Certification



KEMA Certification



ISO9001



ISO14001



OHSAS18001

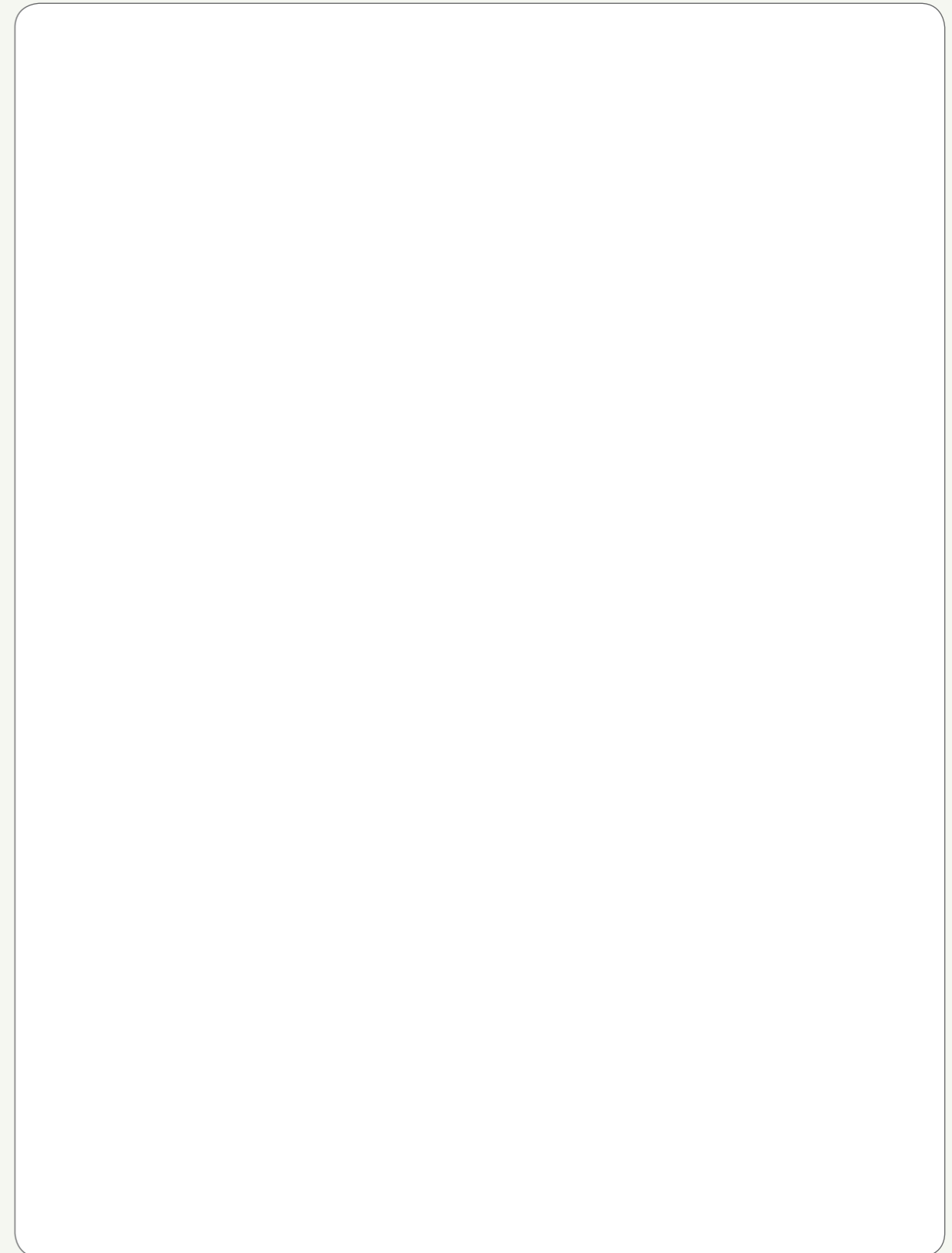

# GLOBAL NETWORK

More than 60 Factories,  
Sales and Production Sites  
in 20 Countries.

- Factory
- Sales office
- Branch office



## KOREA



**Gumi Plant**  
EHV / MV / LV cable  
UTP, Coaxial cable  
SCR, Magnet wire  
Overhead cable, Bus duct



**Indong Plant**  
Optical fiber  
Optical cable



**Donghae Plant**  
Submarine cable  
Industrial specialty cable

## CHINA



**LSHQ(Yichang)**  
EHV / MV / LV cable  
Industrial specialty cable



**LSCW(Wuxi)**  
Industrial devices cable  
Automotive cable  
Harness & module  
Aluminum, Bus duct

## VIETNAM



**LS-VINA(Haiphong)**  
EHV / MV / LV cable  
SCR, ACSR  
Overhead cable



**LSCV(HO Chi Minh)**  
MV / LV cable  
UTP, Optical cable  
Overhead cable

## INDIA



**LSCI(Bawal)**  
EHV / MV / LV cable  
Coaxial cable  
Overhead cable

## USA



**LSCUS(Tarboro)**  
MV / LV cable  
Control, Instrument cable

## POLAND



**LS EV Poland./LSCP (Dzierzoniow)**  
Automotive battery components  
Optical cable



[www.lscns.com](http://www.lscns.com)  
Busduct System

18F, LS Yongsan Tower, 92 Hangang-daero, Yongsan-gu, Seoul, 04386, Korea  
Tel. 82-2-2189-8884 Fax. 82-2-6969-5424

©2020 LS Cable & System Ltd. All right reserved.

This product or document is protected by copyright and distributed under licenses restricting its use, copying, distribution, and recompilation. No part of this product or document may be reproduced in any form by any means without prior written authorization of LS Cable&System and its licensors, if any.

Products shown on this catalog are subject to change without any prior notice.