

LS C&S Busduct System

E-series

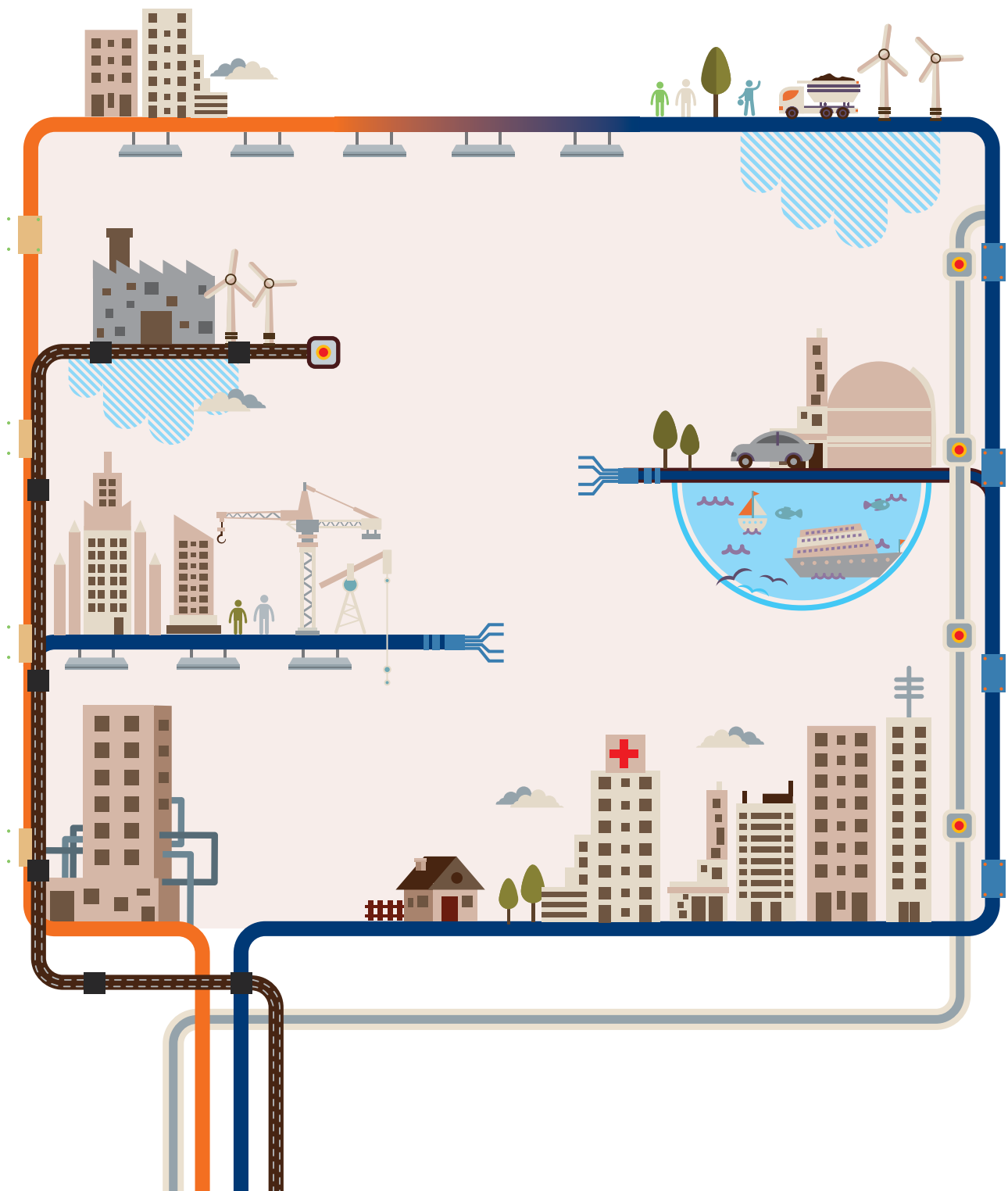

About LS Cable & System

LS spun off from LG in 2003 as a group specializing in the Electrics, Electronics, Energy, and Material. LS consists of about 40 affiliates including LS Cable & System, LSIS, LS-Nikko Copper, LS Mtron, Gaon Cable, E1 and Yesco. A leading player in the global cable industry, with over half a century of experience as a manufacturer, providing consolidated expertise in the design and production of premium quality cabling technologies.



Total Solution Provider for Electric Power and Telecommunication Industries

LS Cable & System, the longtime de facto holding company of LS Group, officially transformed into a holding company in July of 2008. The company's operations now encompass a total solution for electric power and telecommunication industries.

The latest change in corporate structure comes as the company is accelerating efforts to improve management efficiency in rapidly expanding markets. The move also results from efforts to effect a more responsible and transparent management structure. Management is now prepared to take more aggressive action to enhance our businesses and to identify new growth engines. The holding company will take the lead in fostering new growth engines and in identifying lucrative investment opportunities, while the company's other business units will focus on improving management and on making operations more efficient. With the continued support of the holding company, LS Cable & System will spearhead efforts to strengthen our business expertise, corporate competitiveness and management.



LNG, CNG

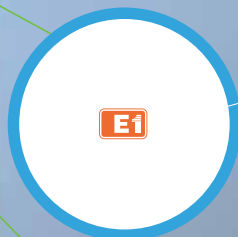

Supply of LPG for residential&commercial, transportation, industrial and petrochemical uses in domestic market. Import & Export of LPG etc.



Components, Machinery



Control Cable, Power Cable, Elevator Cable, etc



Electrolytic Copper Cathode, Gold, Silver, Chemicals Product etc.

Enable the Cabled World!!

LS Cable & System, established in 1962, has been contributing to building power grids and communication networks first in Korea and then in countries all over the world by developing, producing and providing cables and related solutions used in daily life and throughout many industries. Furthermore, the company set the stage for industrial and economic development by capitalizing on our innovative technology to supply various special industrial cables and industrial materials.

We at LS Cable & System are now supplying state-of-the-art products, such as submarine, extra-high voltage, high temperature superconducting and communications cables to power authorities, heavy electric equipment makers and common carriers around the world. Our products can be seen throughout the Americas, Europe, the Middle East and Asia, so we are now recognized as a leading manufacturer serving global industries both in name and reality.

Based on our corporate philosophy, "LS Cable & System Way," we will go beyond simply generating profits to develop forward thinking competencies by innovating our business models, developing environment-friendly high-quality products and reinforcing our partnerships with stakeholders as the best partner that will maximize customer values. We will open a brighter future by innovating and investing in technologies that push the envelope and developing the best total solutions.



LS Cable & System
Leading Solution

LS Cable & System Busduct System Solution



Buildings

The LS C&S Busduct system is easy to install, and ensures large capacity of energy transmission while providing space efficiency which makes the bus duct system ideal for high-rise buildings, office buildings, data centers and apartment complexes.



Plants

The full lineup consists of NSPB, CAST RESIN and SIB that can cover up to 27kV, and the lineup thus enables us to provide our clients customized designs. The system is suitable for electrical rooms and power lines, and it features a real-time monitoring system using the temperature and power monitoring system.



Data Center

The flexibility and expandability as well as easy maintenance property of the busduct system provides the best alternative to improve the existing problems of the conventional power cable system of data centers, which requires constant extension, reinstallation and capacity modification of loads.



Apartment Buildings

Although the demands for more electricity for families are growing, the space for EPS area has reduced. Due to the change, the need for busducts and multi boxes have increased.



Hospitals

The stability of the power supply in the hospitals is perhaps the most vital element, because its failure could threaten the safety of patients.

The Busduct system distributes larger capacity of electric power, and provides stability of the loads which make it an ideal choice to satisfy the requirements of systematization of hospital complexes and larger hospital equipments.



Airports

In order to secure the stable power supply of the airport, the busduct system provides the best customized solutions by installing high voltage busducts at the transmission, transformation and power distribution lines, and by installing low voltage busducts at the cargo, the control tower and general commercial buildings.



Stadiums

The needs for a busducts system has been growing for its benefit such as large capacity of power transmission, providing a stable power supply for various loads and an eco friendly property as well as economical quality.



Marine & Wind

The compact and light weight design of the busduct satisfies the demands of the clients, and comes with an outstanding quack resistance property. The busduct provides stability to the operation of the facilities through a real-time monitoring system using a temperature and power monitoring system. As the needs for renewable energy grows, the demand for our busduct has been increasing steadily.

LS Cable & System Busduct Product Line-up

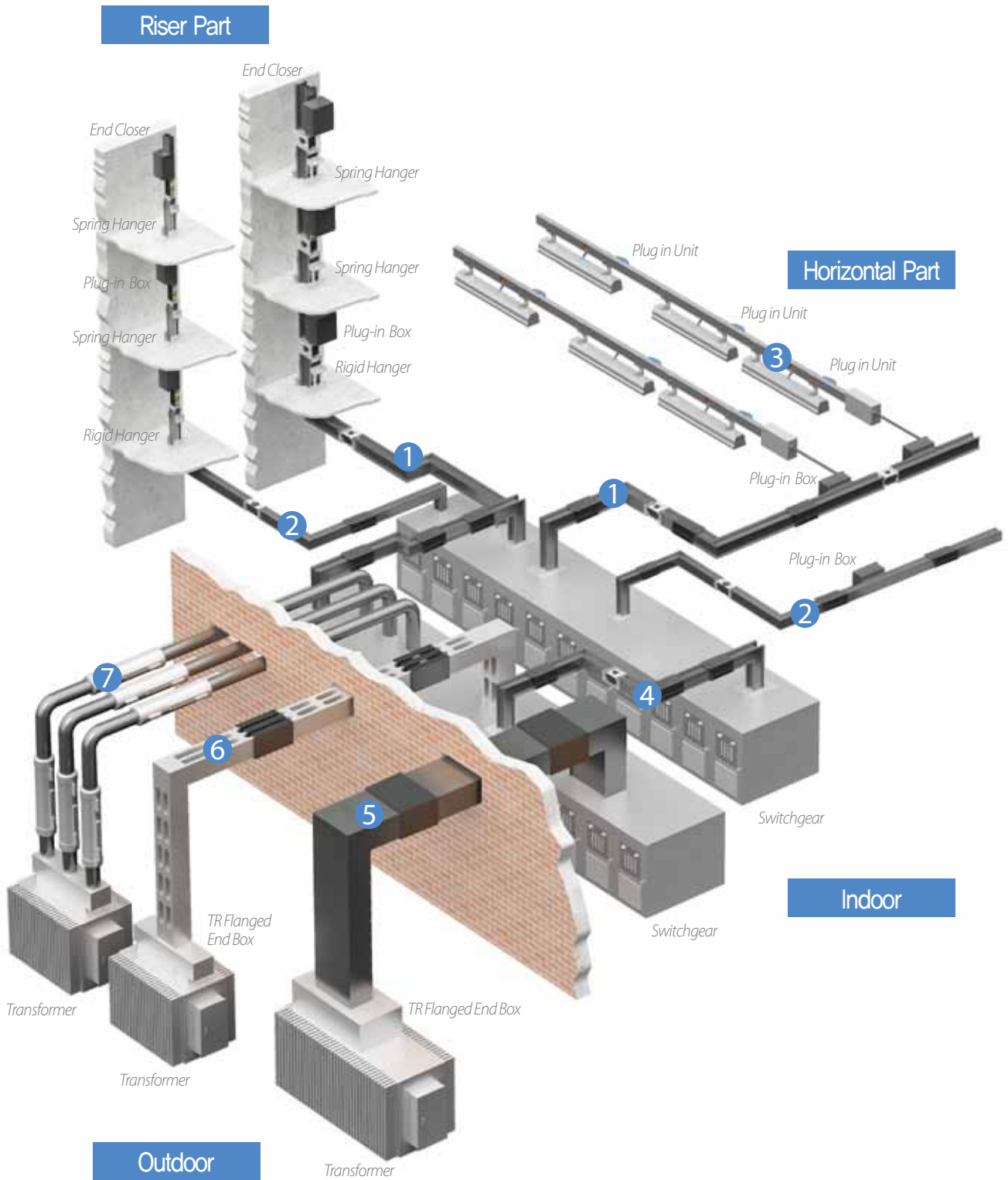

The LS Cable & System Busducts are available in a wide range of products from low current capacity LT-way (25A~63A) to large current capacity (630A~7500A), and the products enable the supply of proper capacity of power for factories and the distribution system. Our products such as the air insulated bus conducts with enhanced safety property and the cast resin busducts with resistance for high temperature, humidity and dusty environment will satisfy various application needs and provide a customized engineering service.

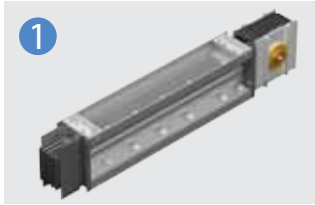

1

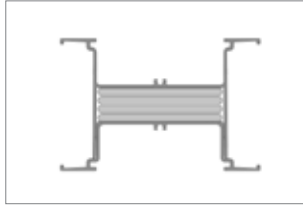

Ez/Ex/Ef-way

Sandwich Type (PET Film, Epoxy Coating, MICA)/AL Extrusion Housing/Standard IP54/Joint Kit

- Designed for low voltage products below AC 1000V, and between 630A to 7500A.
- The most widely used conventional model.

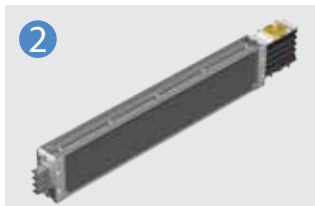

2

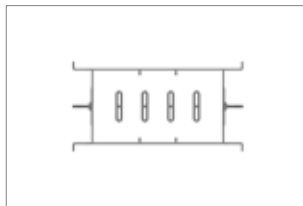

Mini-way

Air Insulated Type/AL Extrusion Housing/Standard IP54/Joint Kit

- Designed for low voltage products below AC 1000V, and between 160A and 800A.
- Ideal for small distribution system with multi distribution loads (Vertical areas of buildings, data centers, assemble factories)



3

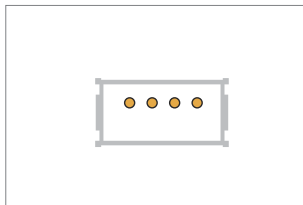

LT-way

Flat Wire Type/Copper Conductor with PVC Extruded Insulation/AL Extrusion Housing/Various Plug Types/Joint Brush (It can be installed with a live wire.)

- Designed for low voltage products below AC 690V, and between 25A and 63A
- Suitable for Light bulbs, FFU and distribution for small equipments



4

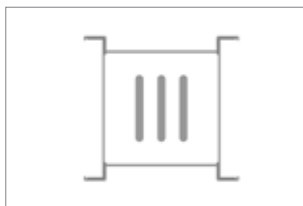

MS/Wind-way

Air Insulated Type/ Compact NSPB Type / One-Bolting Type Designed for low voltage products below AC 1000V, and between 1000A and 5000A

- A Hybrid incorporating NSPB and sandwich type
- Ideal for ships, wind towers and chemical plants where stability is required.



5

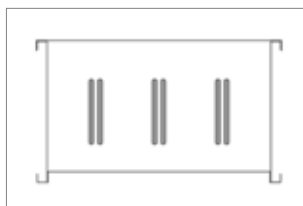

NSPB-LV/MV

Air Insulated Type/Insulated conductors separated by phase/AL, STS and Steel Housing (optional)/Indoor Type/Outdoor Type

- NSPB-LV : Designed for low voltage products below AC 1000V, and below 4000A
- NSPB-MV: Designed for high voltage products below AC 27kV, and below 4000A
- Suitable for plants where high stability is required.



6



CR-LV/MV

- Cast Resin Type/IP 68/Epoxy Molding between Conductors

- CR-LV: Designed for low voltage products below AC 1000V, and between 630A and 7500A.
- CR-MV: Designed for high voltage products below AC 27KV, and below 5000A.
- The most safe bus duct suitable for plants where high stability is required.



7

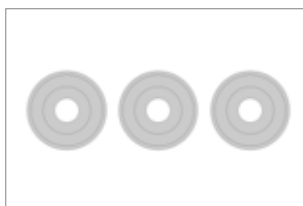

SIB

Epoxy Vacuum impregnated insulation Products/Suitable for phase separation system

- Designed for high voltage products below AC 27kV and below 7500A
- Small space , bending area
- Suitable for high voltage products.

Why Busduct?

Easy Distribution of Loads

When supplying power using cables, each load has to be connected individually to cables which waste space, and an additional distribution panel is also required.

On the other hand, busducts are separated from a single line at a plug box which simplifies the electric power system. A MCCB can be installed at the plug box to effectively shut off fault current.

Cable Wiring System

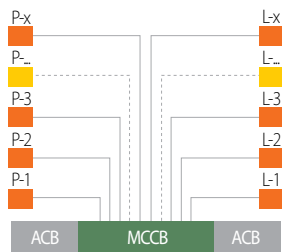

- One-to-one correspondence of power supply and loads
- Additional lines are needed in case of a load change

Busduct Wiring System

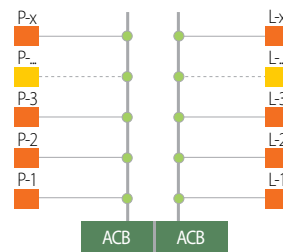

- One-to-many correspondence of power supply for specific power supply
- Additional lines are not necessary in case of a load change

ACB : Air Circuit Breaker, MCCB : Molded Case Circuit Breaker

Easy Installation

Pulling and cable tray installation for cables can be difficult, and requires a longer construction period, therefore increases the cost. On the other hand, the busducts use a simple installation method to connect specific length of products, which requires a shorter installation period, and is economically friendly.

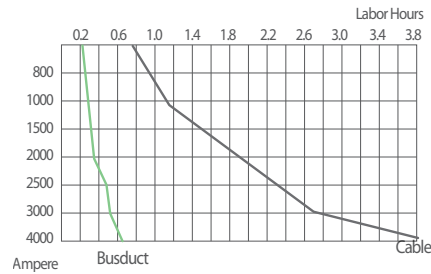

Compact

The compact design of the busduct system provides high space efficiency at up to 50% compared to the cables. While cables require larger space to install multi lines as well as additional space for coiling areas, the busducts use proper fittings to maximize space efficiency.

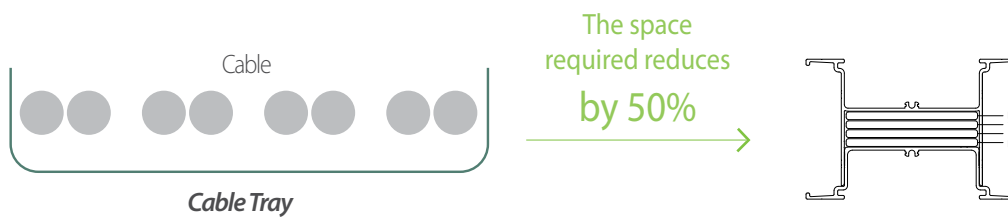

Adaptability to various installation environment with convenience

The busduct system is a power distribution system and can be applied to various complex routes. The busduct system comes with various fittings such as elbow, off-set and tee, and can transmit high capacity currents without electrical and mechanical loss.

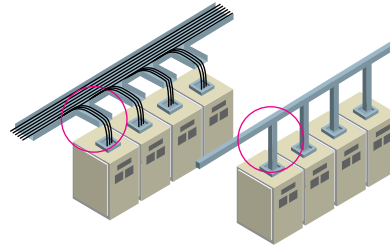

Excellent short circuit strength

The busduct system has a high tolerance for short circuit. Its stability and reliability make it perfect for a high capacity energy transmission system.

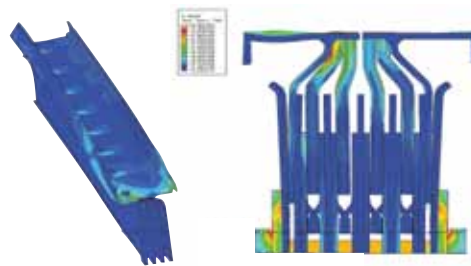

High current density

Cables are connected directly to electric loads using racks. Its maximum allowable current ampacity limit is 1000A, and requires additional lines for a higher current. Each line of the busduct system can transmit up to 7500A, and provides high current density.

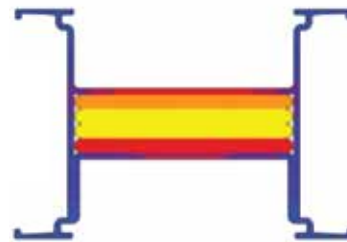

Easy maintenance

The design of the busduct system makes it easy to detect abnormalities during installations, and ensures easy maintenance. When humidity or dust causes a malfunction on the system, the easy-to-maintain design allows replacing only the damaged part.

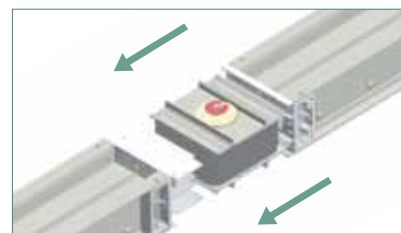

Outstanding features of EMC and EMI

Unlike cables, the busduct system does not require a shield, instead Busduct, the housing itself performs as a shield which enhances the features of EMC and EMI.



Why LS Cable & System Busduct

Global Top Tier

LS Cable & System has been a long-time leading Busduct provider in Korea. With extensive experience and product line competitiveness, the company provides total solutions for each application to satisfy the needs of its clients. Using its expertise in the electronic markets of large LCD monitors and semiconductors in Korea, the company has obtained PJT sales records in 50 countries worldwide in Asia, the Middle East, CIS, and America.

Full Line - up

LS Cable & System is the only global company that provides a full line-up of busducts, from low to high voltage and from low to high capacity, to satisfy every need of its clients and provide an optimized solution for each PJT.

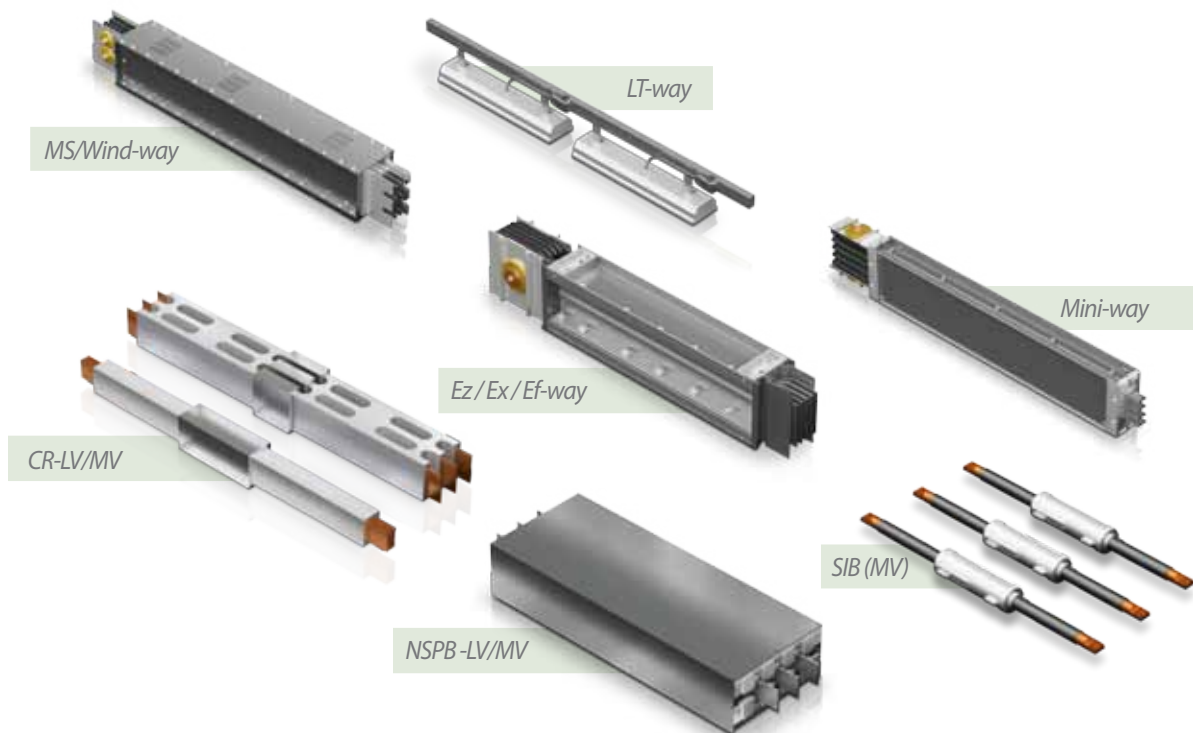

Total Solution

- Once PJT launches, our engineer will participate to guide the clients from the initial period in order to produce the best system for our clients, and to respond quickly when the system is changed.
- Our engineers from each department provide full support in design, production, installation and testing at in-bound to satisfy our clients.
- We operate the CS Team, a task force for the busduct system, to make sure efficient after-sale service and maintenance service.

Process

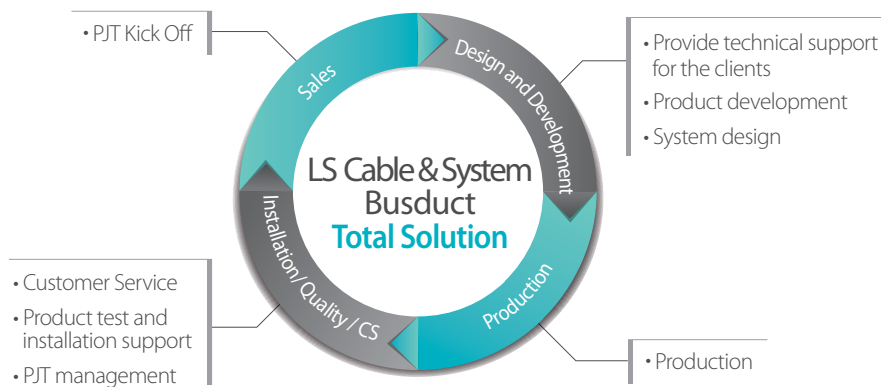

Technical Excellence

Unparalleled Reliability

- Provides standardized design, and owns numerous certifications such as UL Certification, Quack Proof Certification, and Impact Resistance Certification
- The CS team, a task force for the busduct system, provides efficient after-sale service
- Safe use in hazardous zones
- Manage the system using a unique temperature monitor sensor
- Semi-permanent service life
- Used qualified insulation such as epoxy and PET film for efficient insulation

Eco friendly

- Fully recyclable
- Halogen free
- Does not contain RoHS 6 hazardous substance
- No toxicity in fire & Fire-Retardant
- Non Explosive

Total Engineering Technology

- Provide the optimal design by experienced engineers
- Design following analysis and inspection of CAE
- Unique and exclusive design program for the busduct system
- Design based on structure stability inspection
- The excellent heat –radiating property of the aluminum housing, which ensures large capacity of power transmission
- Low Weight & Low cost
- Easy installation
- Deployable where access is difficult
- Automated epoxy insulation facility
- Unique joint kit connections
- Reduce electromagnetic
- BPMS (Busduct Power Monitoring system)
- BTMS (Busduct Temperature Monitoring system)

The Busduct Temperature Monitoring System (BTMS : Busduct Temperature Monitoring System)

The busduct is a large capacity power distribution system. The insulation of the duct has to stay stable when the Joule lines occur during a power supply of the conductor. The rated current will be set by the insulation type and the temperature rises. These properties of the busduct make it possible to monitor and manage abnormalities of the system by checking the temperature of specific areas of the system.

The temperature monitoring system uses various temperature sensors such as optical fiber cable, IC electric chips and thermo-graphic cameras. Specific areas like the entire system line, joints, plug-in boxes and cable connection can be monitored at the central monitor room using various methods on request.

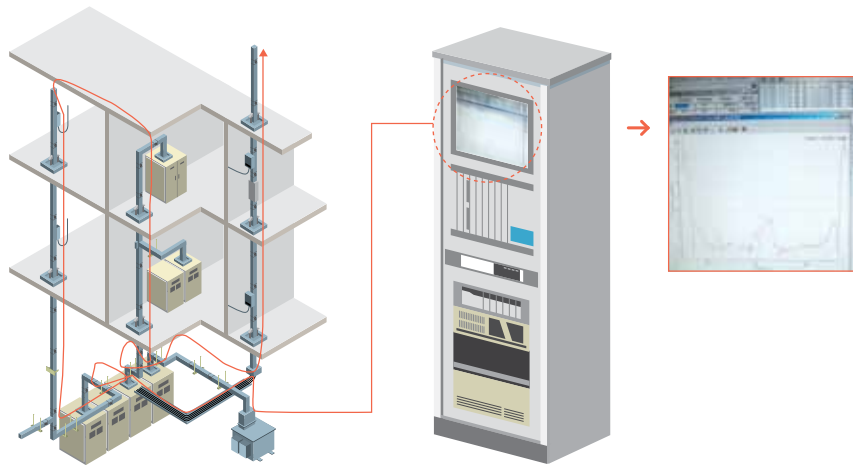

The Busduct Power Monitoring System (BPMS : Busduct Power Monitoring System)

The ongoing trends of the busduct system are more than a simple power supplying system. The growing trend is; 1) the stability of the power system, 2) unmanned system, 3) cost cutting, and 4) green and smart grid. While the SCADA system monitors and controls the power of the main system, the BMS monitors low loads of the sub system. The frequency of the recent electrical accidents is higher at the sub system than at the main system. Therefore, the preference for the BMS system has been increasing.

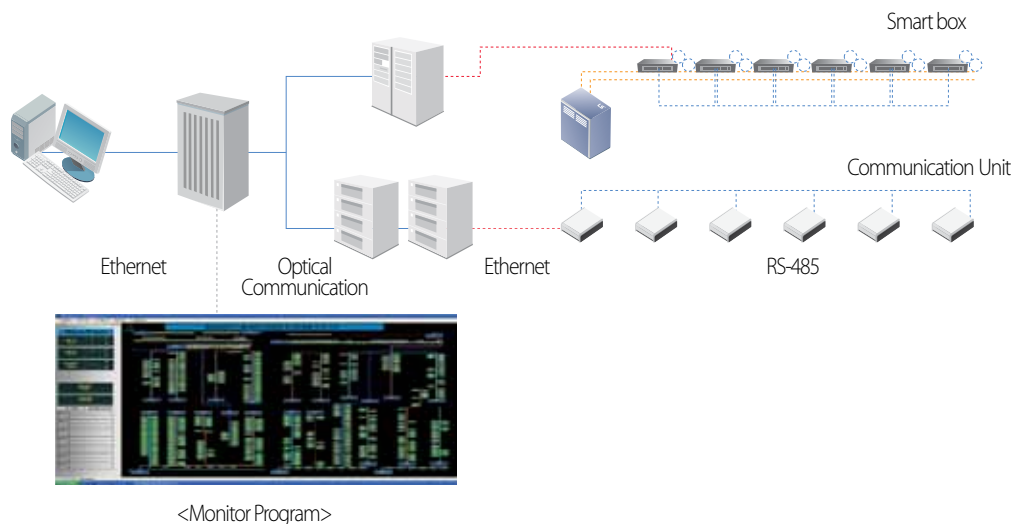

Ez/Ex/Ef-way

LS C&S Busbuct System Catalogue

01 of 08

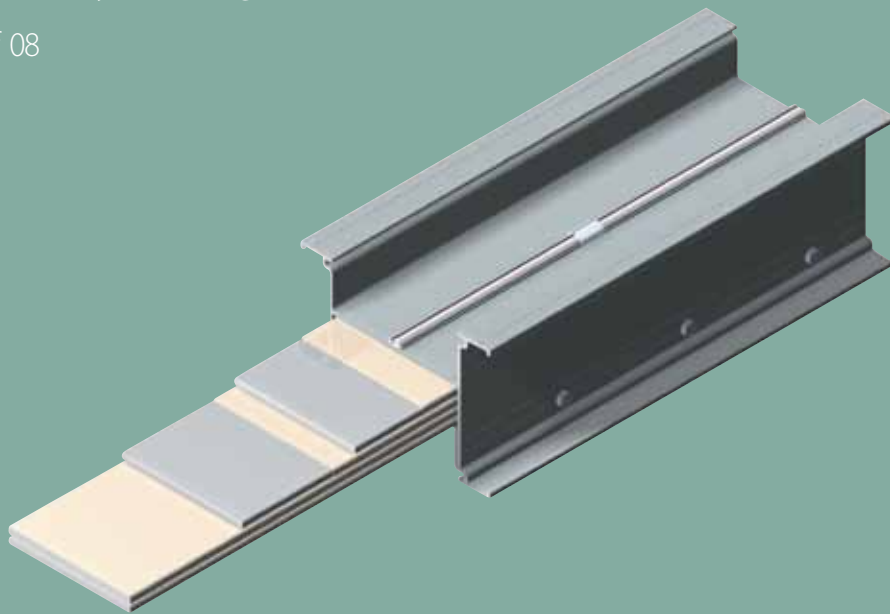

Contents

I. Introduction	
- Overview	14
- Application	15
II. General Data	16
III. Component	
- Feeder	22
- Flanged End	23
- Fittings	26
- Hanger	29
- Plug-In Unit	31
- Etc	33
IV. Technical Data	
- Impedance	35
- Voltage Drop	35
- Temperature Rise	37
V. Install Information	
- Joint Connection	38
VI. Certification & Specification	39

Overview

The E-Series

The LS C&S E-Series Busducts are designed to carry voltage range below AC 1000V, and to carry the current range of 630A to 7500A. Joint kit connections provide more space to connect which reduce the contact resistance to its minimum while connecting products. LS C&S E-series Busduct comes with a standard IP54 rating; however, it can be upgraded to an indoor or outdoor IP65 rating on request. E-Series Busducts have three different types of insulation using polyester film, mica film, or epoxy powder.

Compact Size

LS C&S E-Series Busduct uses an effective heat radiating housing profile which allows the size of the conductors to be smaller than the existing Busduct models. The light weight of the Busduct also allows easier installation and requires less space.

Economical and Easy Installation

LS C&S E-Series Busduct uses aluminum housing and joint kit connections which enable easy installation with less time and low cost.

Easy Distribution of Loads

LSC&S E-Series Busduct can directly distribute the loads at the plug-in box using a single line, and thus simplifies the power supply system. The MCCB can be installed in the plug-in box on request to effectively shut off the fault current.

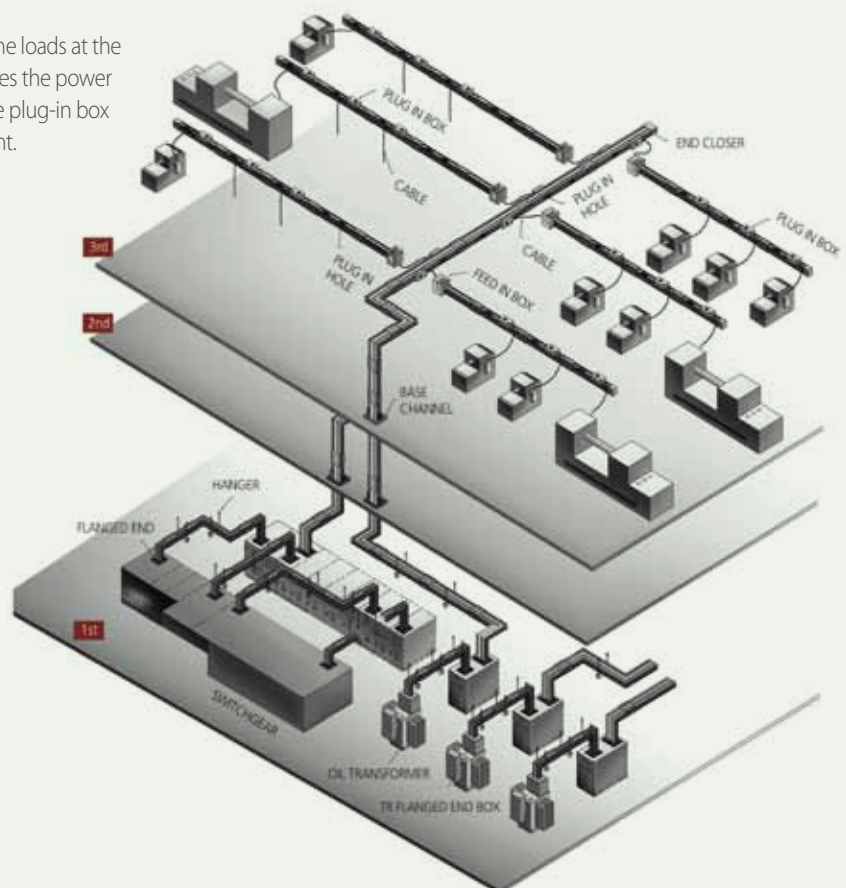

Application



Electrical Rooms

- The busduct can be installed both horizontally and vertically at the electrical room.
- The maximized safety features are seismic-proof and explosion-proof.
- Provides excellent space efficiency and easy installation compared to cables.

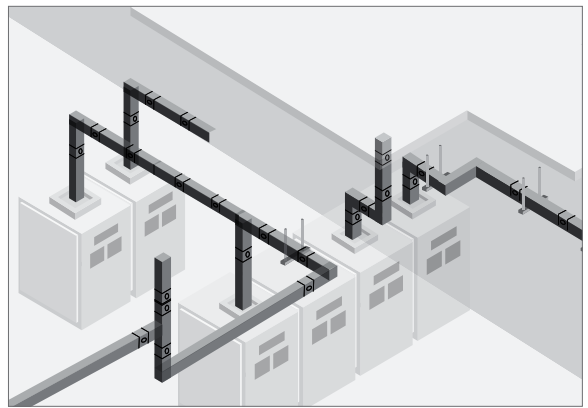

Commercial / Housing Building etc.

- Provides excellent space efficiency.
- The busducts can be applied to high-rise buildings, office buildings, and data centers.
- Multi-box can be applied on request.

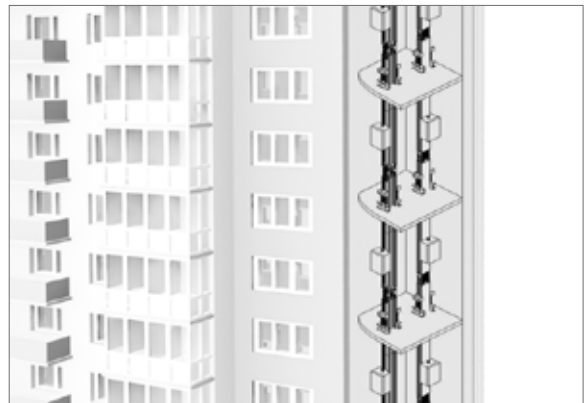

Factory / Plant etc.

- The busducts can be applied to a vast range of industries such as semiconductor, display and petrochemical plants.
- The temperature and the power supply monitoring system allows easy maintenance.
- The busducts provides high space efficiency, and allows a significantly reduced installation period.

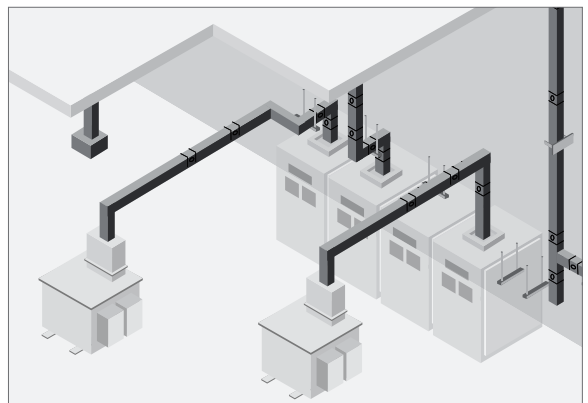

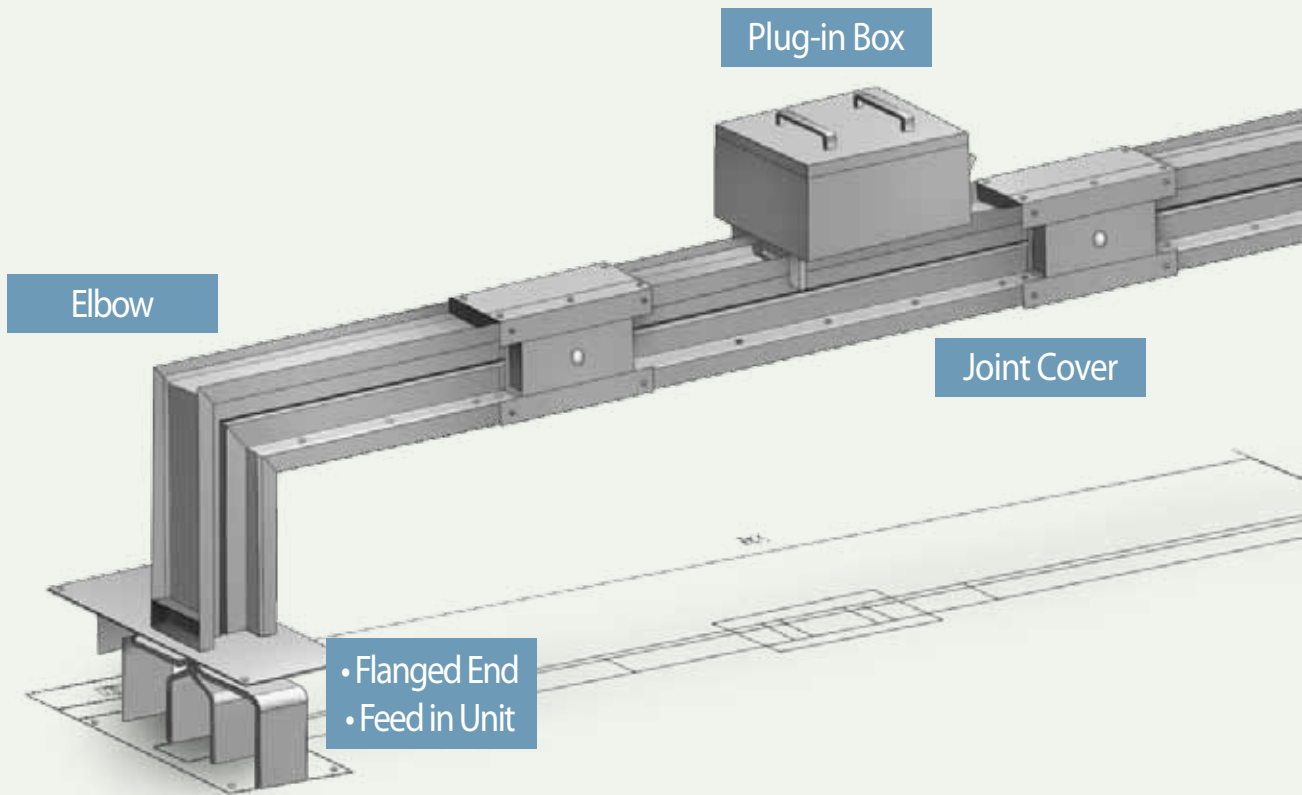

High Current Density

The busduct has a compact design compared to the existing models by using an effective heat-radiating housing profile and can carry from 630A up to 7500A with reduced loss of electric power. It is an ideal power distribution system that provides high efficiency, stability, economy-friendliness and convenience. The design of the conductor allows flexibility to extend and relocate depending on the environment.



Eco - Friendly

The LS C&S Busducts acquired RoHS certification, and only uses components without hazardous substances such as lead, cadmium, mercury, chrome, PBBs and PBDEs.



Low Voltage Drop and High Short Circuit Strength

Thanks to the optimum design, power can be transmitted with the greatest possible efficiency, and the resultant voltage drop is low due to extremely low impedance. In addition, the LS C&S Busducts is designed to have very high short circuit strength.



Standard

- IEC 61439-1 [(previous standard)IEC 60439-1] Power Switch gear and Control gear Assemblies
- IEC 61439-6 [(previous standard)IEC 60439-2] Busbar Trunking Systems
- BS EN 61439 Busways
- NEMA BU 1.1 Busways



Permissible Operating Temperature

The cross sectional areas of the conductor and housing profile are designed to meet the standard permissible operating temperature of IEC 61439-1 and 6. Therefore the temperature rise limit of the housing is within 55K or less of the ambient temperature.



Service Condition

- Ambient Temperature : -15 °C ~ 55 °C
- Relative Humidity : 95% or below
(When the service condition of the environment does not meet the requirements listed above, please contact our design team.)

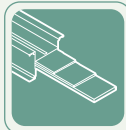
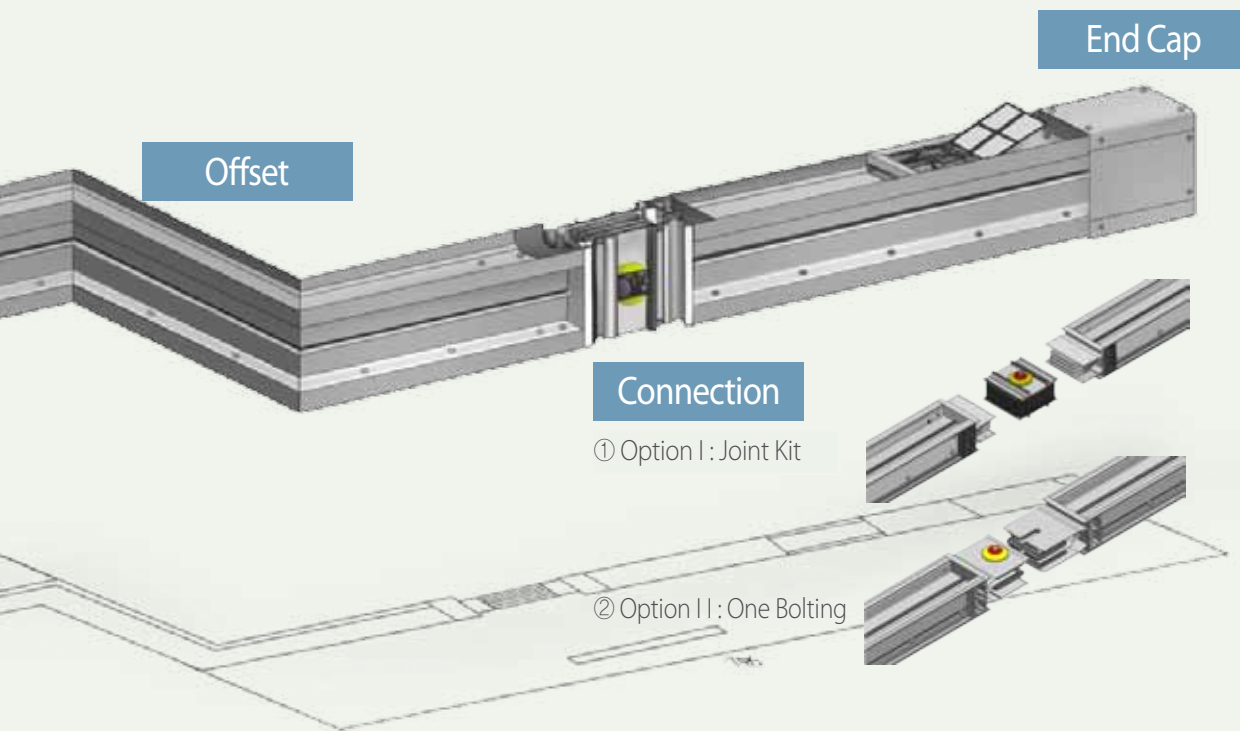

Conductors

The E-Series uses either copper conductors with conductivity over 98% and purity over 99.9%, or aluminum conductor with conductivity over 61% and purity over 99.6%

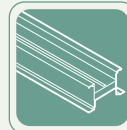

Housing

The E-Series uses an effective heat-radiating aluminum housing profile which produces an excellent mechanical strength and heat radiation. The aluminum housing can be used as a protective conductor(PE) due to its high level conductivity and cross sectional areas. An optional optical fiber temperature sensor can be installed at the housing.



Insulation Properties

An insulator of thermal class rating Class B (130 °C) or more is applied to the E-Series. Other insulation options such as Epoxy, PET and MICA (Fire proof up to 1200 °C) are also available. FRP (Fiber Reinforced Plastic) with high dielectric property is used as insulation at the connection which performs as insulation between phases and housing.

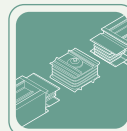

Connection

- **Kit** : DH (dual head) bolts and Visible-label (Redtag)
Check for installation using the contact
To exert a uniform force on the entire connection can Disc Spring A structure. (Assembly Torque 800 ~ 1000kgf.cm)
- **One-bolting** : One-bolting without a Feeder Kit Part of the structure is directly connected to the conductor, Kit with the same DH (dual head) bolts and Visible-label (Red-tag) to Check for the installation and use of all contacts Connection can apply a uniform force to the Disc Spring A structure. (Assembly Torque 800 ~ 1000kgf.cm)

General Specifications

E-series Busduct uses insulation with a thermal class rating over 130 °C for each phase. A sandwich type design is applied to the Busduct to protect the aluminum housing, and it can be used at the voltage range of AC 1000V or less, and the current range between 630A to 7500A. It is designed to use a joint kit connection and general IP54 rating.

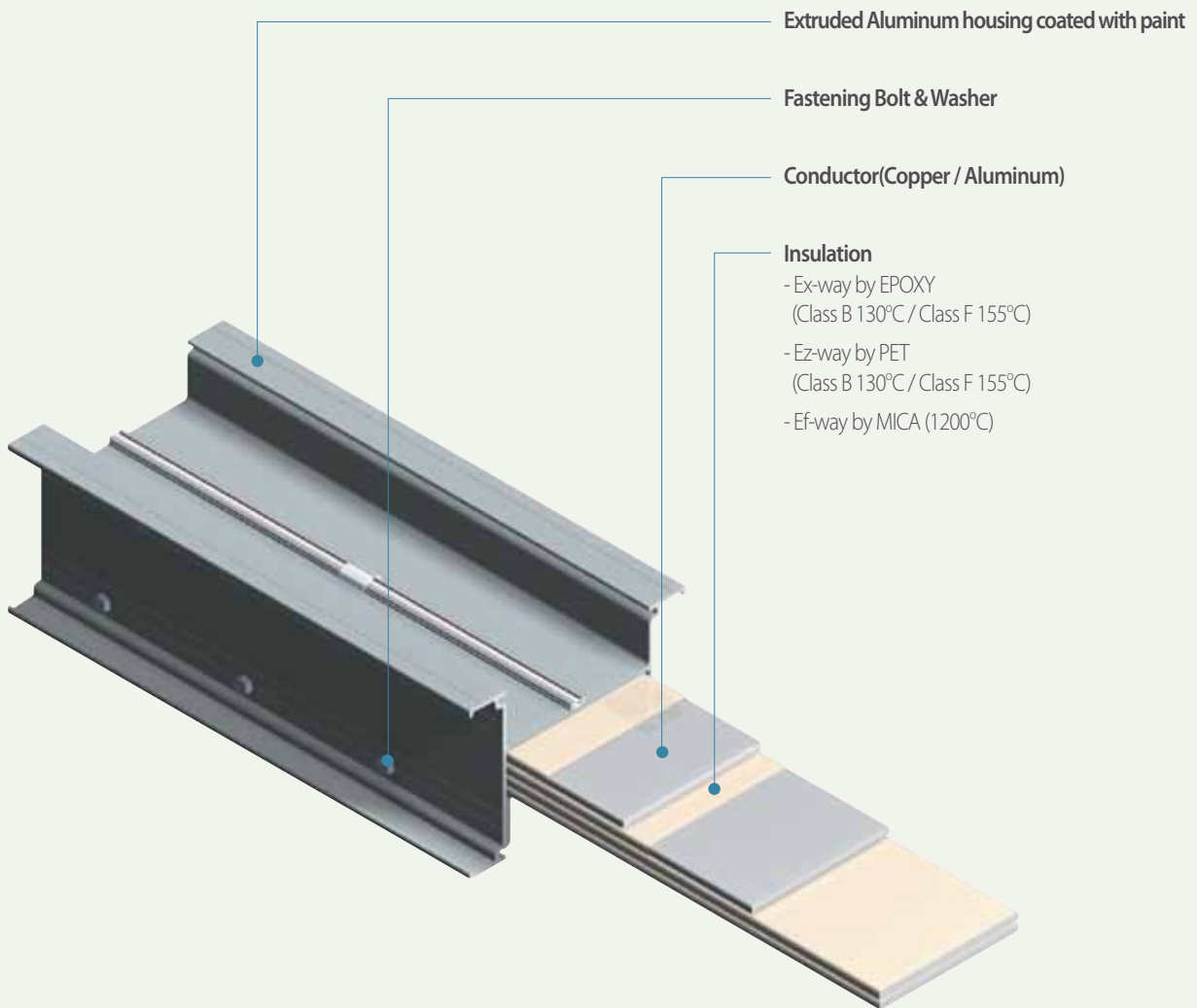

Joint Connection

Feature

Both joint plates of the joint kit and the conductors are tin plated. (A silver plated option is available.) It prevents the joint plate from discoloration and corrosion. In order to ensure easy maintenance and reliability, double-headed bolts and visible labels are used to check the application, and a disc spring allows even connection of the contact surface.



Double Headed Bolts

Double-headed bolts are used to ensure a proper torque level when installing the joint kit. If a torque wrench applies a pressure of 800 to 1000kgf·cm to the outer bolt head, the head of the outer bolt and the tag attached to it will be sheared off automatically. Thus, it allows visual inspection for the proper application of the bolts at the connection. The remaining bolt head can be re-used when tightened to 800kgf·cm using a torque wrench.

<Option I : Joint Kit>

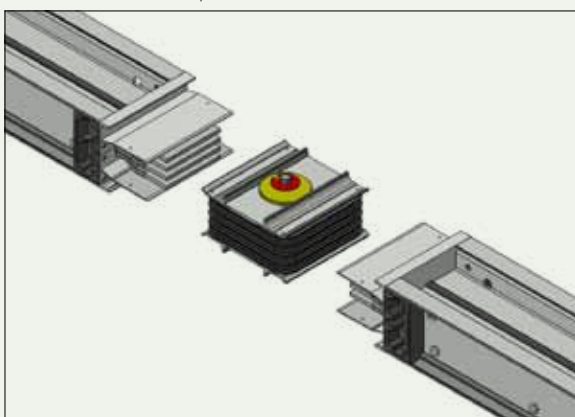

<Option II : One Bolting>

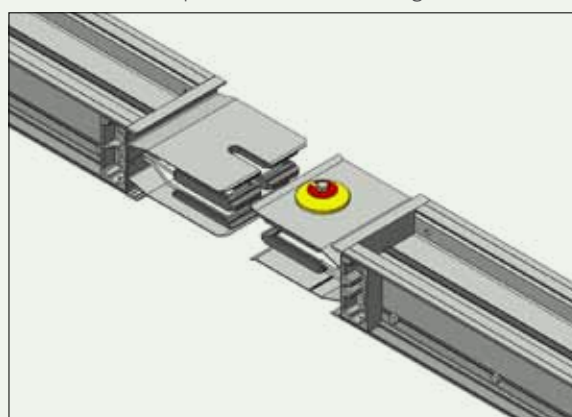

Number of Double headed bolts

Number of D.H bolts		1	2	4	6
Ampere (A)	CU	630, 800, 1000, 1250, 1600, 2000	2500, 3200, 3600, 4000	5000	6300, 7500
	AL	630, 800, 1000, 1250	1600, 2000, 2500	3200, 3600, 4000	5000, 6300

! Precaution

Be sure to clean the interior of the connections prior to installation. Use caution not to twist the joint kit while inserting it, and after it is inserted. An excessive pressure during installation may break the kit. Make sure that the double-headed bolts and the red tags are intact. If proper torques are not applied at the connection, it may cause heat during operation.

Grounding and Harmonics

E-Series Busduct comes with aluminum housing, and the cross-section area of the housing is over 100% of each phase conductor. Therefore, the aluminum housing alone works as 100% or more of ground bar, and the housing also improves the heat radiation of the conductors.

If increased ground capacity is required, additional internal ground bars can be added to the assembly, providing a 50% or 100% increase in ground path.

The 200%N type Busduct is used for a nonlinear load that generates harmonic current. Lately, the needs for non-linear loads at the power distribution system of buildings are increasing due to the increase of office automation and computer facilities. The harmonic current produced by the system can flow more than 100% of over current at phase N. The LS C&S 200% N type busduct is safe to be used at the distribution system where the harmonic current can be generated.

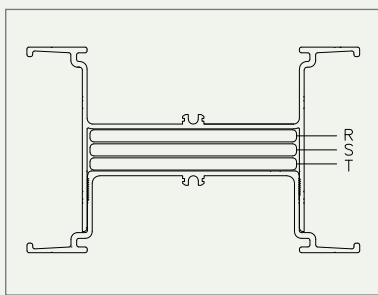

[3W+GE]

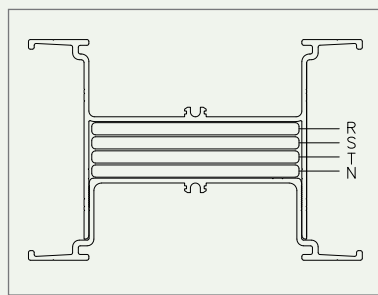

[4W+GE]

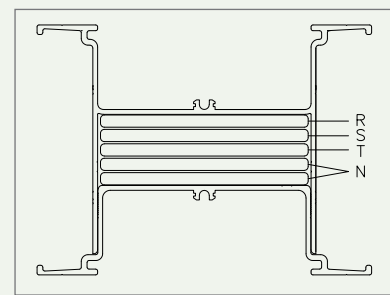

[4W(200%N)+GE]

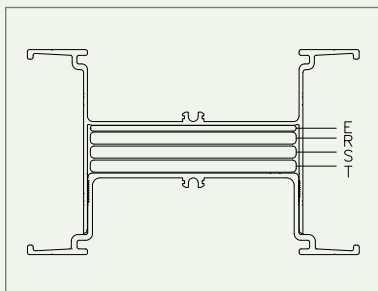

[3W+50%E, 100%E]

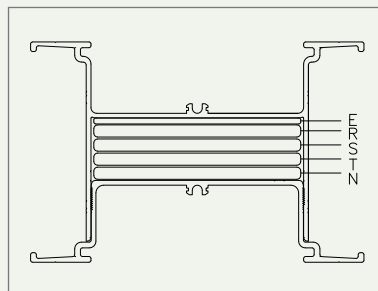

[4W+50%E, 100%E]

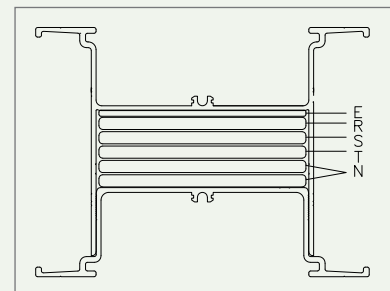

[4W(200%N) + 50%E]

Plating/Painting

Plating

Standard tin plating is applied at taps, plugs and connections of conductors using an electroplating method to maintain the electrical characteristics and to prevent corrosion. Silver plating is available on request.

Painting

In order to improve heat radiation and to prevent corrosion, as well as to fit in with the surroundings, we apply polyester-epoxy (hybrid) power coating after treating the surface. A wide range of color is available to meet the needs of our clients.

IP Code (Degree of Protection)

International protection degree codes provided by IEC 60529(Degree of Protection Provided by Enclosure-IP Code)

NEMA STANDARD : • IP54=NEMA 12, 12K, 13 • IP55=NEMA 3, 3X, 3S, 3SX • IP66=NEMA 4, 4X • IP67=NEMA 6







* As the standard differs, it is a similar substitution, not 1:1 substitution.

The degree of protection against water of the LS C&S E-Series is a standard IP54; however, it can be adjusted from IP42 to IP65 depending on the environment and on request.









IP



Solid Particle Protection

-  **0 No Protection**
-  **1** Protection against 50mm diameter solid particles. (back of a hand)
-  **2** Protection against 12mm solid particles. (fingers)
-  **3** Protection against 2.4mm solid particles. (tools or thick wires)
-  **4** Protection against 1mm solid particles. (tools or most wires)
-  **5** Protection against dust.
-  **6** Complete protection against dust.

Liquid Ingress Protection

-  **0 No Protection**
-  **1** Protection against falling drops of water.
-  **2** Protection against falling drops of water with an enclosure tilted at a 15 degree angle from a vertical line
-  **3** Protection against spray at a 60 degree angle from a vertical line
-  **4** Protection against water splashed from all directions.
-  **5** Protection against low pressure jets of water from all directions.
-  **6** Protection against strong jets of water from all directions.
-  **7** Protection against the effects of immersion between 15.0 centimeters and 1.0 meter.
-  **8** Protection against longer periods of immersion under pressure.

Degree of Protection IP54

IP54 is applied to the feeder, plug-in and tap-off, and can be used during water leakages and near sprinklers.

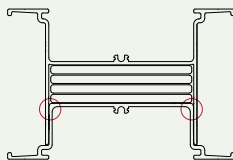

Indoor

Degree of Protection IP55/IP65 (Indoor/Outdoor)

With the IP65 rating, the busduct is ideal for corrosive environments. The special sealing between the housing sections seals off water, dust and gasses.

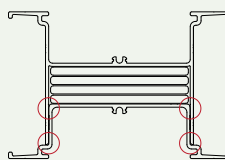

Indoor Type
(IP55/65)

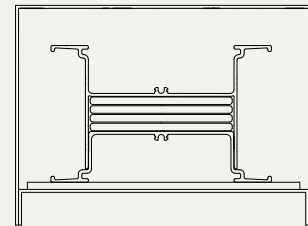

Outdoor Type
(IP65)

Feeder

Sectional View

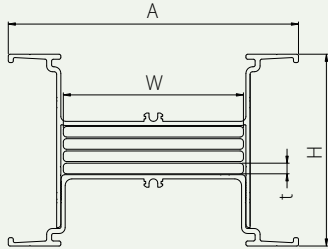

[Fig.E1-1]

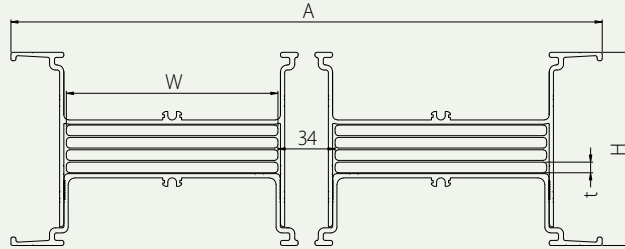

[Fig.E1-2]

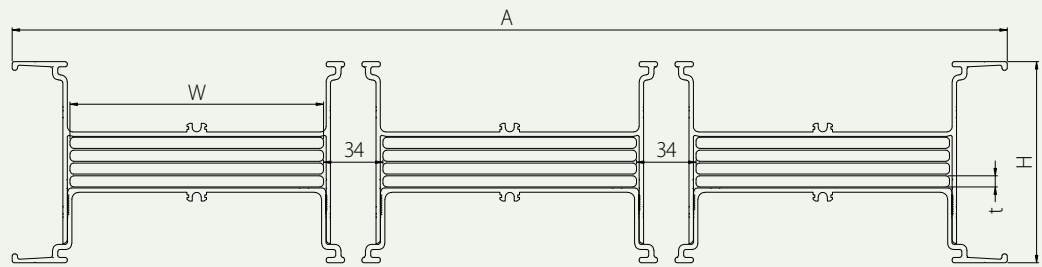

[Fig.E1-3]

Ampere(A)	Dimension(mm)			Weight(kg/m)				Fig.	
	t	W	A	3W	4W	4W+50%E	4W+100%E		
AL	630	6.35	41	107	7.58	8.43	8.79	9.15	E1-1
	800		62	128	8.83	10.09	10.63	11.17	
	1,000		86	152	10.92	12.14	12.89	13.64	
	1,250		108	174	13.40	15.42	16.36	17.30	
	1,600		164	230	19.57	20.61	22.08	23.55	
	2,000		210	276	23.08	26.23	28.14	30.09	E1-2
	2,500		(2)126	352	28.94	33.18	35.38	37.58	
	3,200		(2)164	428	34.86	42.44	45.29	48.14	
	3,600		(2)184	468	38.31	45.40	48.59	51.78	
	4,000		(2)210	520	41.81	50.10	53.75	57.40	
5,000	(3)184	686	57.74	68.43	73.22	78.01	E1-3		
6,300	(3)210	764	64.03	73.61	81.51	89.41			
CU	630	6.35	41	107	11.91	14.44	15.65	16.86	E1-1
	800		41	107	11.91	14.44	15.65	16.86	
	1,000		57	123	14.65	18.25	20.58	22.91	
	1,250		73	139	17.65	22.04	24.60	27.16	
	1,600		108	174	26.74	31.00	36.47	41.94	
	2,000		145	211	31.69	37.39	44.76	52.13	E1-2
	2,500		195	261	42.69	54.59	60.25	65.91	
	3,200		(2)108	316	50.16	63.60	69.87	76.14	
	3,600		(2)126	352	57.55	73.16	80.41	87.66	
	4,000		(2)145	390	64.82	82.72	91.17	99.62	
	5,000		(2)195	490	85.26	109.14	121.08	133.02	E1-3
	6,300		(3)164	626	108.91	139.27	154.65	168.02	
	7,500		(3)195	719	126.89	162.81	179.83	196.85	

* H: 107.5(3W+GE, 3W+50%E) / 115(4W+GE, 4W+50%E) / 130(4W+100%E)

Flanged End

Flanged end is connected to either a transformer or panel. Dimension details are listed below.

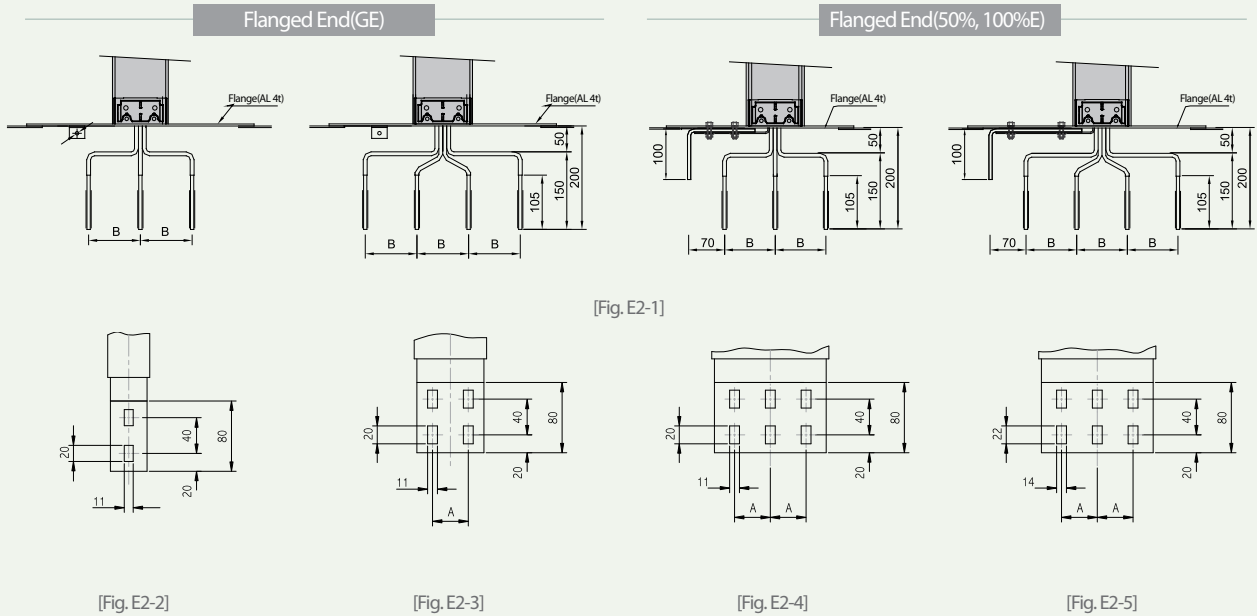

Ampere(A)	Dimension(mm)				Fig.	
	t	W	A	B		
AL	6.35	41	~	100	E2-2	
		62	~			
		86	40			
		1,250	108	50	130	E2-3
		1,600	164	60		
		2,000	210	70		
		2,500	(2)126	40		E2-4
		3,200	(2)164	60		
		3,600	(2)184	60		E2-5
		4,000	(2)210	70		
		5,000	(3)184	60		
6,300	(3)210	70				
630	41	~	100	E2-2		
800	41	~				
1,000	57	~				
1,250	73	40		E2-3		
1,600	108	50				
2,000	145	50		E2-4		
2,500	195	70				
3,200	(2)108	50		130	E2-3	
3,600	(2)126	40				
4,000	(2)145	50			E2-4	
5,000	(2)195	70				
6,300	(3)164	60	E2-5			
7,500	(3)195	70				

*T: Conductor thickness

Flanged End

Drilling Pattern for Flanged End

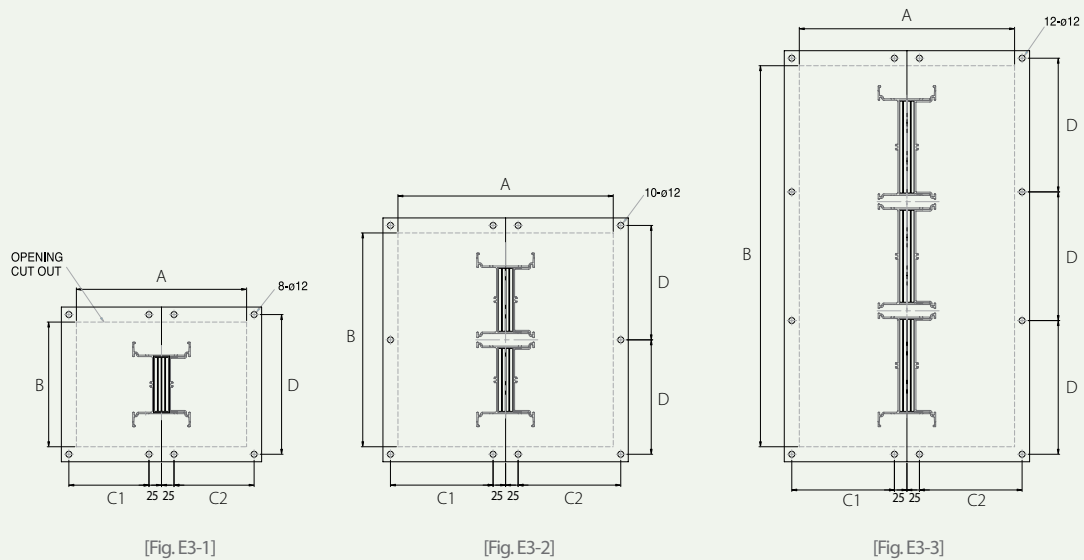

Ampere(A)	3W Dimension(mm)				4W Dimension(mm)				4W+50%E, 100% E Dimension(mm)					Fig.	
	A	B	C1, C2	D	A	B	C1, C2	D	A	B	C1	C2	D		
AL	630	240	122	110	152	340	122	160	152	410	122	230	160	152	E3-1
	800	240	143	110	173	340	143	160	173	410	143	230	160	173	
	1,000	240	167	110	197	340	167	160	197	410	167	230	160	197	
	1,250	240	189	110	219	340	189	160	219	410	189	230	160	219	
	1,600	240	245	110	275	340	245	160	275	410	245	230	160	275	
	2,000	240	291	110	321	340	291	160	321	410	291	230	160	321	E3-2
	2,500	300	367	140	199	430	367	205	199	500	367	275	205	199	
	3,200	300	443	140	237	430	443	205	237	500	443	275	205	237	
	3,600	300	483	140	257	430	483	205	257	500	483	275	205	257	
	4,000	300	535	140	283	430	535	205	283	500	535	275	205	283	
5,000	300	701	140	244	430	701	205	244	500	701	275	205	244	E3-3	
6,300	300	779	140	270	430	779	205	270	500	779	275	205	270		
6,300	300	779	140	270	430	779	205	270	500	779	275	205	270		
CU	630	240	122	110	152	340	122	160	152	410	122	230	160	152	E3-1
	800	240	122	110	152	340	122	160	152	410	122	230	160	152	
	1,000	240	138	110	168	340	138	160	168	410	138	230	160	168	
	1,250	240	154	110	184	340	154	160	184	410	154	230	160	184	
	1,600	240	189	110	219	340	189	160	219	410	189	230	160	219	
	2,000	240	226	110	256	340	226	160	256	410	226	230	160	256	E3-2
	2,500	240	276	110	306	340	276	160	306	410	276	230	160	306	
	3,200	300	331	140	181	430	331	205	181	500	331	275	205	181	
	3,600	300	367	140	199	430	367	205	199	500	367	275	205	199	
	4,000	300	405	140	218	430	405	205	218	500	405	275	205	218	
	5,000	300	505	140	268	430	505	205	268	500	505	275	205	268	E3-3
6,300	300	641	140	224	430	641	205	224	500	641	275	205	224		
7,500	300	734	140	255	430	734	205	255	500	734	275	205	255		
7,500	300	734	140	255	430	734	205	255	500	734	275	205	255		

Flanged End Box / Feed in Box

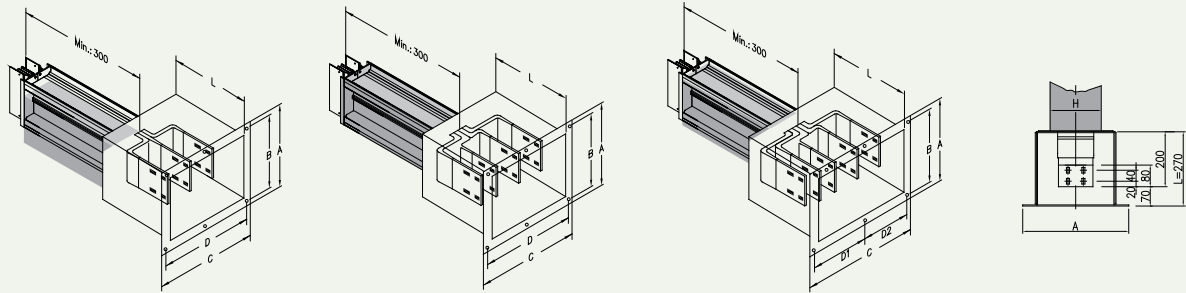

[Fig. E4-1]

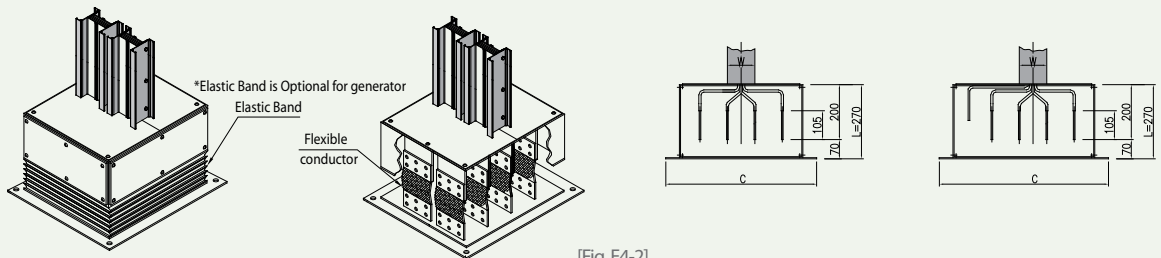

[Fig. E4-2]

Ampere(A)	3W Dimension(mm)					4W Dimension(mm)					4W+50%E, 100% E Dimension(mm)						
	A	B	C	D	L	A	B	C	D	L	A	B	C	D1	D2	L	
AL	630	347	297	410	180X2	270	347	297	510	230X2	270	347	297	580	300	230	270
	800	368	318	410	180X2	270	368	318	510	230X2	270	368	318	580	300	230	270
	1,000	392	342	410	180X2	270	392	342	510	230X2	270	392	342	580	300	230	270
	1,250	414	364	410	180X2	270	414	364	510	230X2	270	414	364	580	300	230	270
	1,600	470	420	410	180X2	270	470	420	510	230X2	270	470	420	580	300	230	270
	2,000	516	466	410	180X2	270	516	466	510	230X2	270	516	466	580	300	230	270
	2,500	592	542	470	210X2	270	592	542	600	275X2	270	592	542	670	345	275	270
	3,200	668	618	470	210X2	270	668	618	600	275X2	270	668	618	670	345	275	270
	3,600	708	658	470	210X2	270	708	658	600	275X2	270	708	658	670	345	275	270
	4,000	760	710	470	210X2	270	760	710	600	275X2	270	760	710	670	345	275	270
	5,000	926	876	470	210X2	270	926	876	600	275X2	270	926	876	670	345	275	270
6,300	1004	954	470	210X2	270	1004	954	600	275X2	270	1004	954	670	345	275	270	
CU	630	347	297	410	180X2	270	347	297	510	230X2	270	347	297	580	300	230	270
	800	347	297	410	180X2	270	347	297	510	230X2	270	347	297	580	300	230	270
	1,000	363	313	410	180X2	270	363	313	510	230X2	270	363	313	580	300	230	270
	1,250	379	329	410	180X2	270	379	329	510	230X2	270	379	329	580	300	230	270
	1,600	414	364	410	180X2	270	414	364	510	230X2	270	414	364	580	300	230	270
	2,000	451	401	410	180X2	270	451	401	510	230X2	270	451	401	580	300	230	270
	2,500	501	451	410	180X2	270	501	451	510	230X2	270	501	451	580	300	230	270
	3,200	556	506	470	210X2	270	556	506	600	275X2	270	556	506	670	345	275	270
	3,600	592	542	470	210X2	270	592	542	600	275X2	270	592	542	670	345	275	270
	4,000	630	580	470	210X2	270	630	580	600	275X2	270	630	580	670	345	275	270
	5,000	730	680	470	210X2	270	730	680	600	275X2	270	730	680	670	345	275	270
6,300	866	816	470	210X2	270	866	816	600	275X2	270	866	816	670	345	275	270	
7,500	959	909	470	210X2	270	959	909	600	275X2	270	959	909	670	345	275	270	

Fittings

E-Series Busduct has a wide range of fittings to satisfy any layout of buildings. Elbow angles other than 90° are also available. Fitting designs are shown in the following figures, and they consist of the source-side and the load-side. Offset or combination elbows can be used where standard elbows are not feasible. (Dimensions for each fitting are shown in the following figures. Contact our design team for a minimum dimension.)

Elbow

[Horizontal]

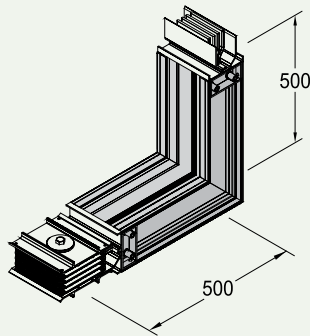

[Vertical]

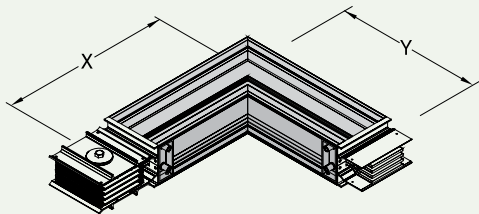

Offset

[Horizontal]

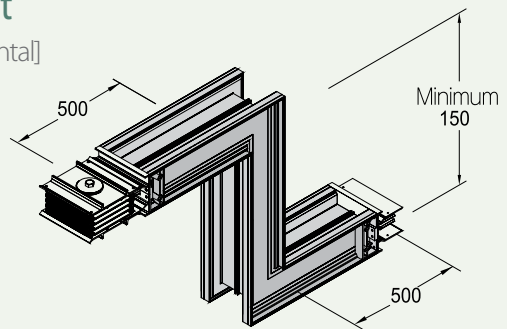

[Vertical]

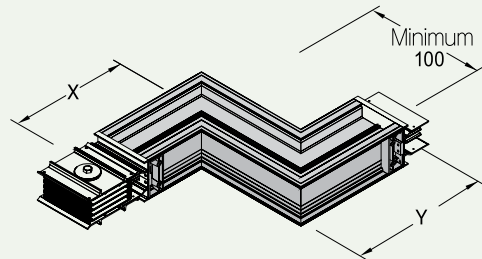

Vertical Elbow

	Ampere(A)	Dimension(mm)	
		X	Y
AL	630~1,250	500	500
	1,600~3,200	600	600
	3,600~4,000	700	700
	5,000~6,300	800	800
CU	630~2,000	500	500
	2,500~4,000	600	600
	5,000~6,300	700	700
	7,500	800	800

Vertical Offset

	Ampere(A)	Dimension(mm)		
		X	Y	Z
AL	630~1,250	500	150	500
	1,600~3,200	600	150	600
	3,600~4,000	700	150	700
	5,000~6,300	800	150	800
	7,500	800	150	800
CU	630~2,000	500	150	500
	3,000~4,000	600	150	600
	5,000~6,300	700	150	700
	7,500	800	150	800

Combination

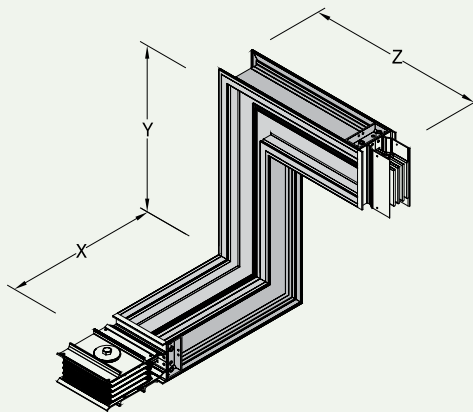

Ampere(A)		Dimension(mm)		
		X	Y	Z
AL	630~1,250	500	500	500
	1,600~3,200	600	600	600
	3,600~4,000	700	700	700
	5,000~6,300	800	800	800
CU	630~2,000	500	500	500
	3,000~4,000	600	600	600
	5,000~6,300	700	700	700
	7,500	800	800	800

Tee

[Horizontal]

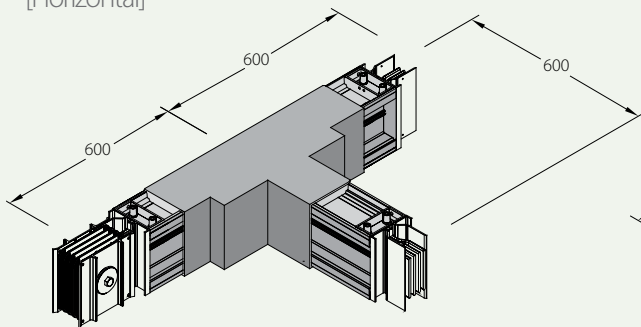

[Vertical]

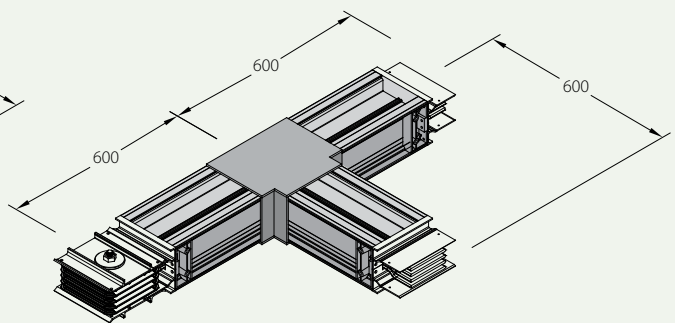

Vertical Tee

Ampere(A)		Dimension(mm)		
		X	Y	Z
AL	630~1,250	500	500	500
	1,600~3,200	600	600	600
	3,600~4,000	700	700	700
	5,000~6,300	800	800	800
CU	630~2,000	500	500	500
	3,000~4,000	600	600	600
	5,000~6,300	700	700	700
	7,500	800	800	800

Fittings

Expansion

The fitting is designed to allow a 60mm extension of a straight line.

Ampere(A)	Dimension(mm)	
	X	Y
630~7,500	1,500	360

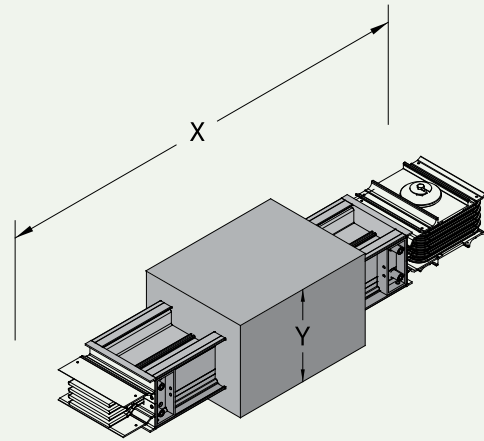

Reducer

A reducer is used to connect a large capacity busduct to a small capacity busduct. It can be used for an economical setup to distribute loads.

Ampere(A)		Dimension(mm)
Primary	Secondary	
1,000	630~800	1,000
1,250	800~1,000	
1,600	1,000~1,250	
2,000	1,250~1,600	
2,500	1,600~2,000	
3,200	2,000~2,500	
4,000	2,500~3,200	
5,000	3,200~4,000	
6,300	4,000~5,000	
7,500	5,000~6,300	

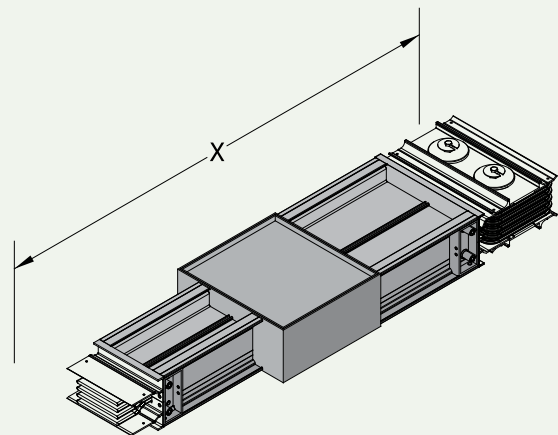

*Any change made to load distribution or to capacities follows inner line regulations. An overcurrent circuit breaker can be installed on request.

Phase Transposition Feeder

A phase transposition feeder is used when the setup transforms the phase.

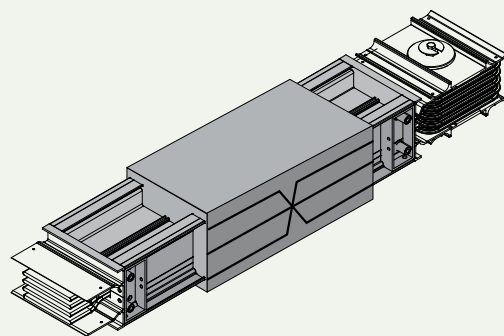

Hanger

Vertical Mounting Hangers

Spring hangers are used to support the busducts between floors. The number of springs depends on the weight of the installed busduct and plug-in boxes. A medium hanger should be installed if the height between the floors exceeds 4.5 meters, and the height of the installed spring hangers can be easily adjusted. Rigid hangers (no spring type) are used on the lowest floor, and they can be used instead of spring hangers depending on the set up design.

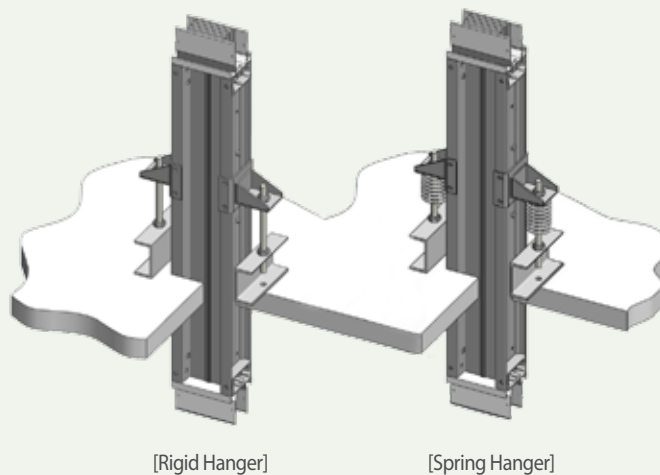

Rigid Hanger

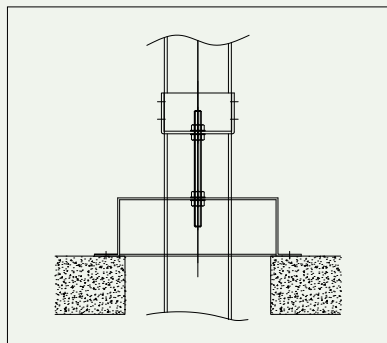

[1 Row]

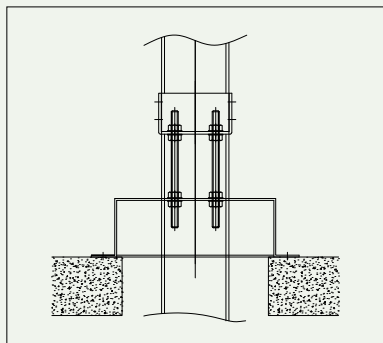

[2 Row]

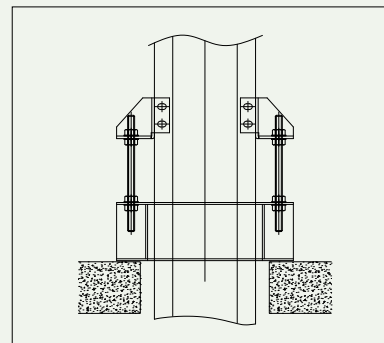

[Side View]

Spring Hanger

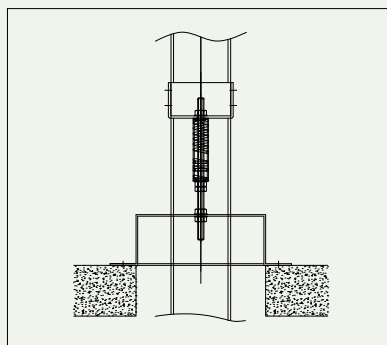

[1 Row]

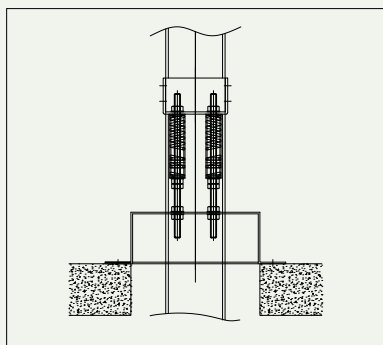

[2 Row]

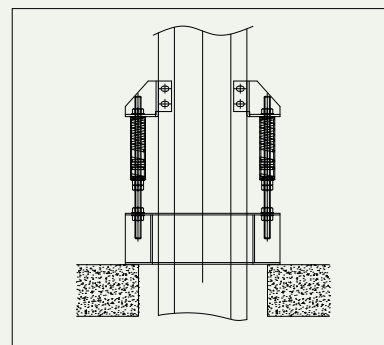

[Side View]

* Hangers with more than 2 rows depending on the installation environment are also available on request. Please contact the design team for further information.

Hanger

Horizontal Hangers

General Hangers

The standard installation method for these hangers is to install them horizontally at 1.5 meters intervals. They generally require 12mm diameter stud bolts.

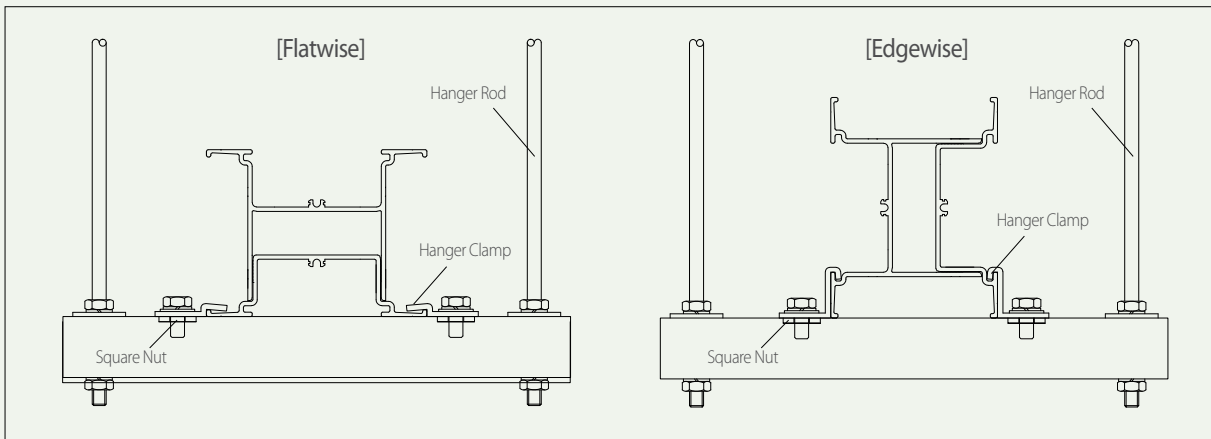

Wall Bracket

Wall brackets can be installed on a wall where general hangers are not feasible.

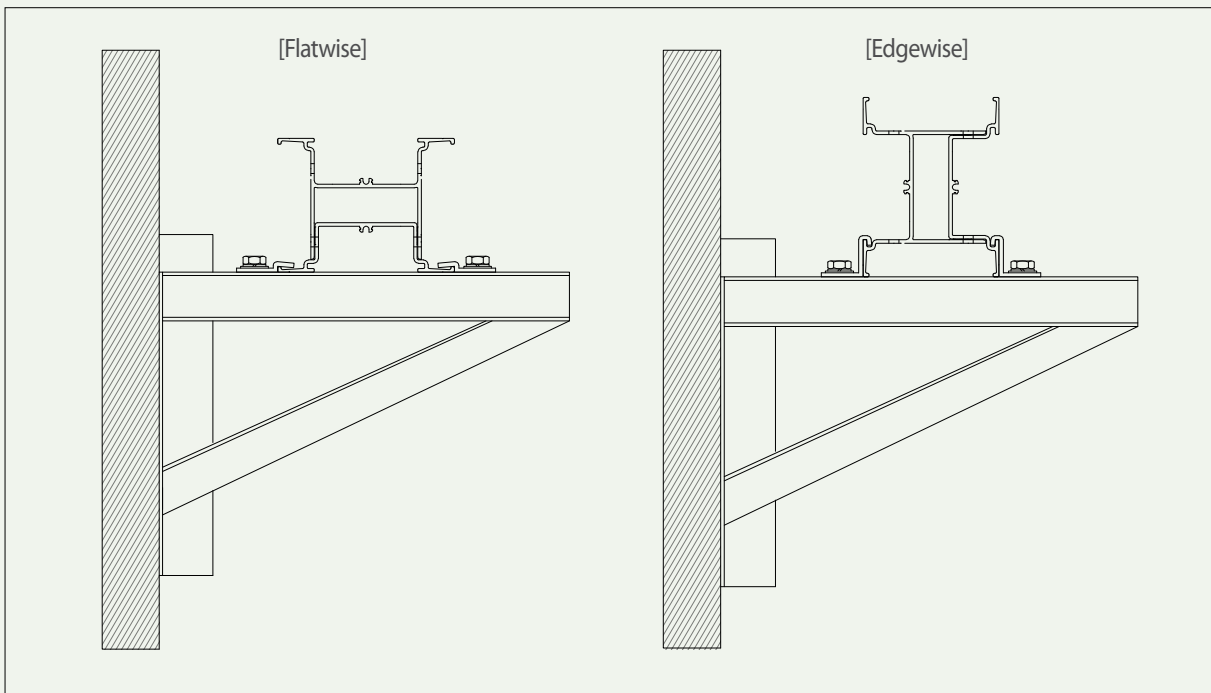

Plug-in Unit

Straight Lengths: Plug-in / Tap-off Intervals

This busduct comes with an overcurrent blocking device (MCCB, fuse) in order to protect the wires while distributing loads.

The required minimum intervals of a plug-in(800A or less) and a tap-off(1000A, 1250A, 1600A) are shown below.

A length longer than the required minimum intervals can be predestinated on request.

Plug-in Feeder

MCCB Frame (AF)	Plug-in Hole Intervals(P) (mm)
50, 125, 250	650
400	900
630, 800	1,000
1000, 1250	1,300

Plug-in Box

MCCB Frame (AF)	Dimensions(mm)				Fig.
	W		D	H	
125	200	230	200	360	E5-1
250	200	230	200	360	
400	230	280	200	800	
630, 800	300	370	200	800	E5-2
1000, 1250, 1600	400	450	230	1200	

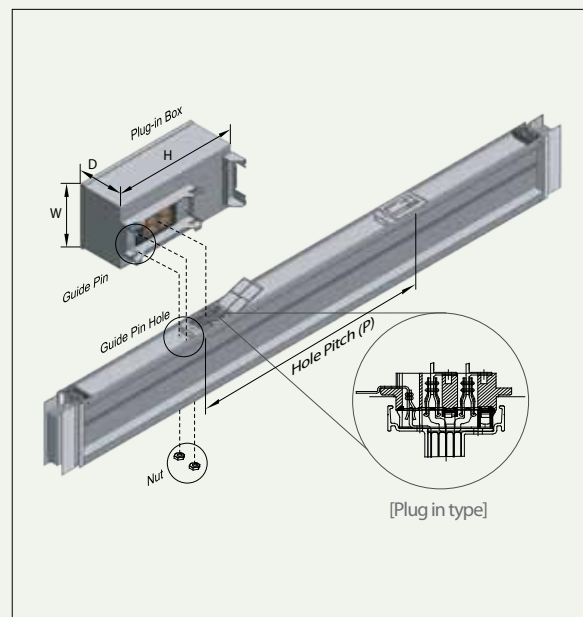

[Fig. E5-1]

Inspection Pin

This pin is used to check the insertion of the box.

*Available from 400AF box

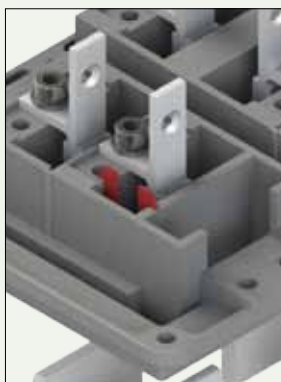

[Before]



[After]

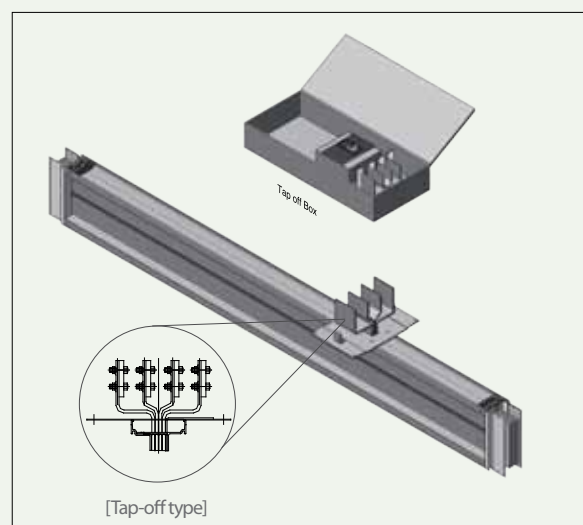

[Fig. E5-2]

Plug-in Unit

Plug-in Box Attachments

Attachments such as CT,TD and PT can be installed in a plug-in box to control and to supervise the current, voltage and wattage remotely.

Door Types of the Plug-in Unit

Various design of doors for the plug-in box is available to satisfy the demands of our clients. The available types are shown below.

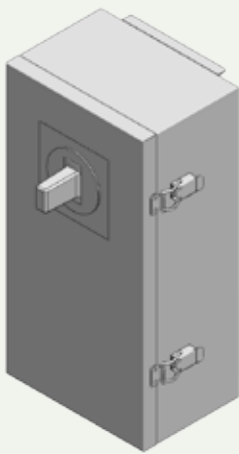

External handle

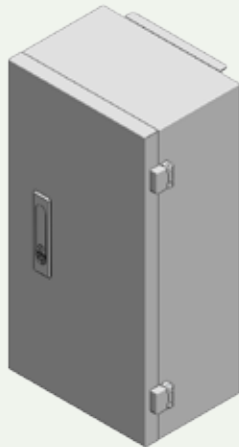

Push Button

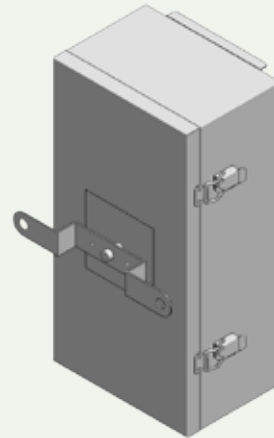

External lever interlock



Bolt Fastening

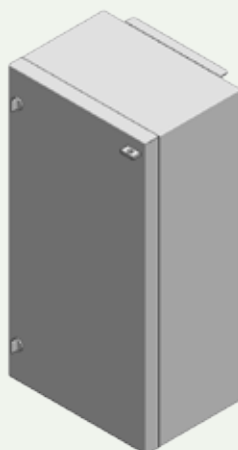

Key Lock



Outlet

Etc.

Wall Flange

A wall flange is used to seal the gaps produced during installation of busducts at the walls, ceilings and floor. The standard dimensions of a wall opening should be 30mm larger than the external dimensions of the E-Series Busduct.

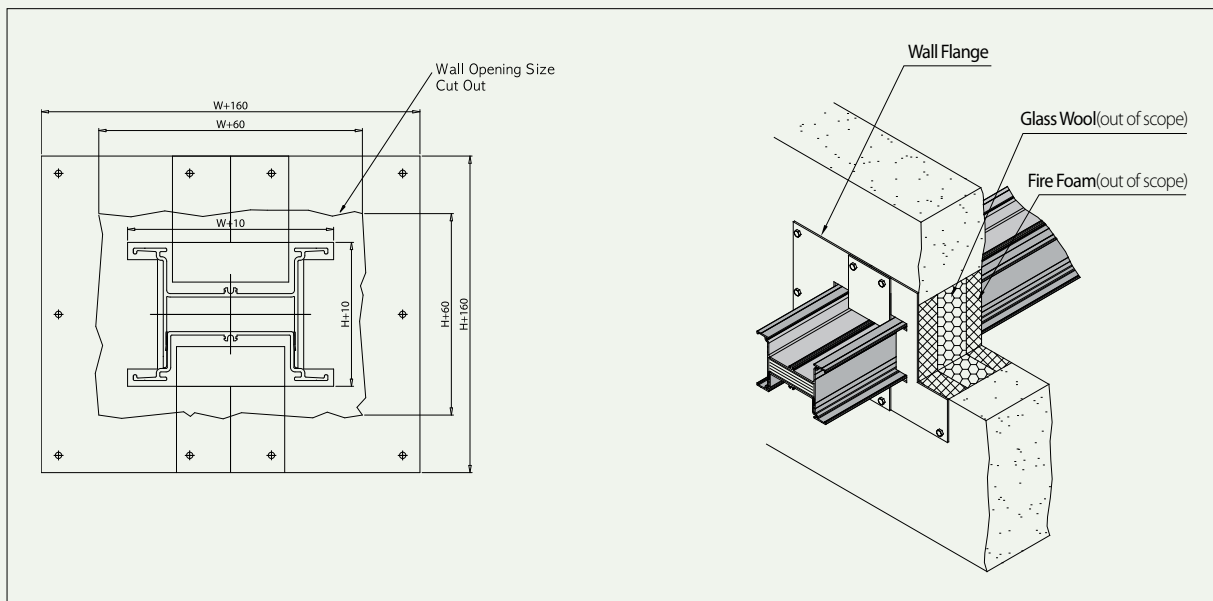

Floor Openings

The standard dimensions of a floor opening should be 30mm larger than the external dimensions of the E-Series Busduct.

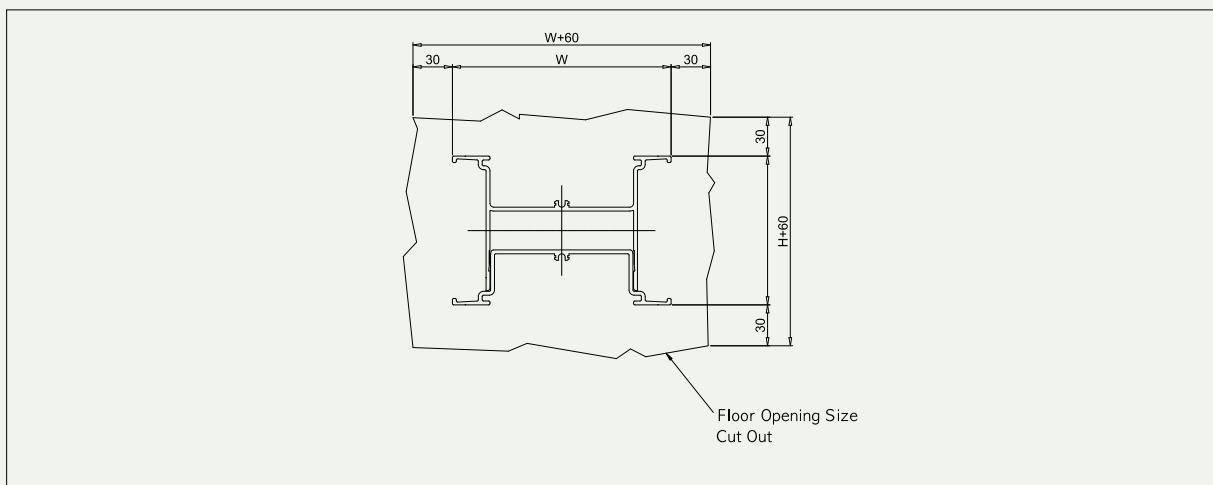

Etc.

The Required Minimum Distances from a Wall for Heat Dissipation and Maintenance

The required minimum distances between a busduct and a wall, or a ceiling are shown below.

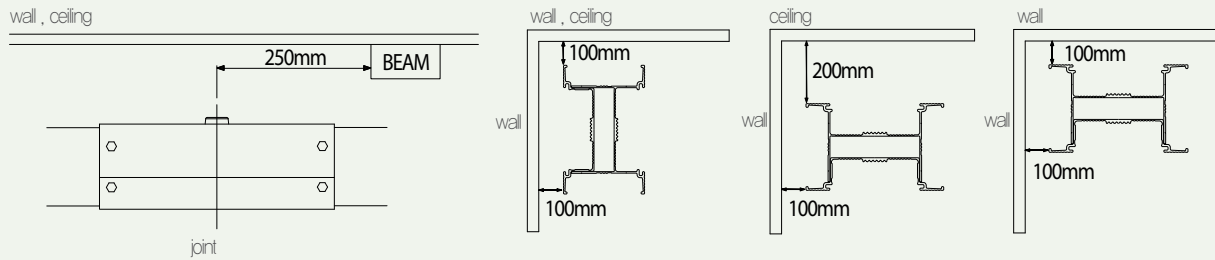

The required minimum distances between busducts

The required minimum distances between busducts are shown below.

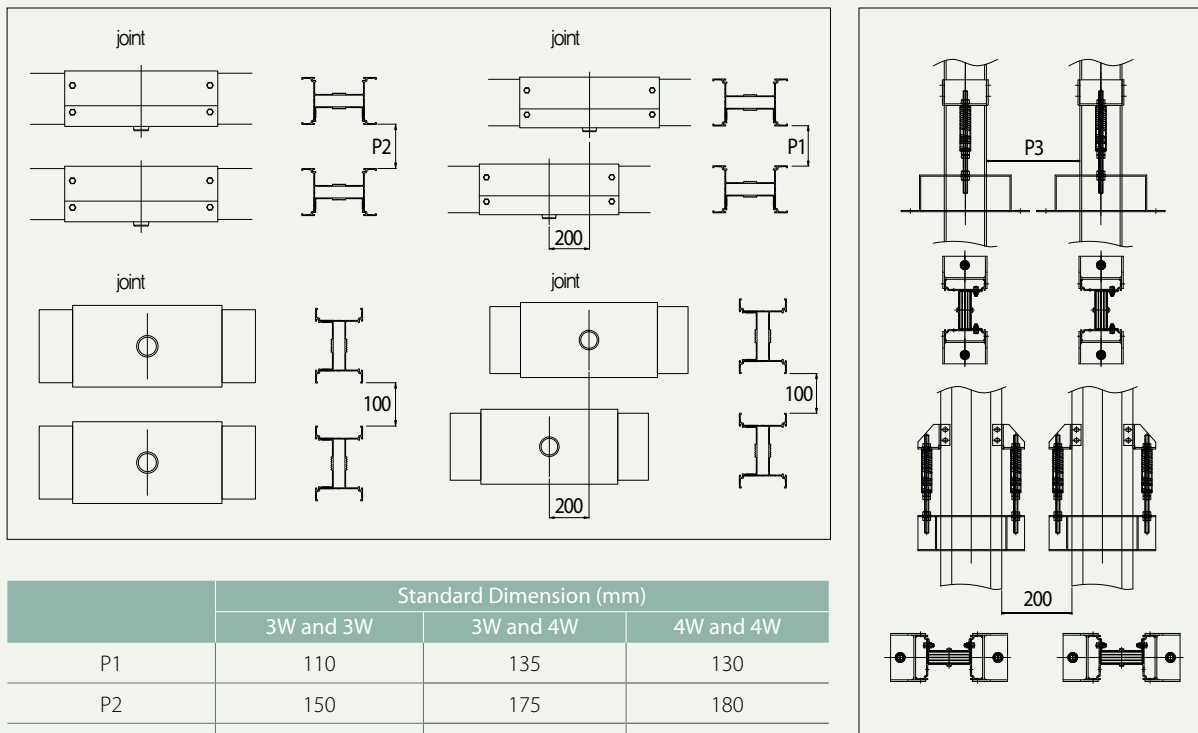

*Outdoor installation requires a further discussion with our design team about proper distance.

Technical Data

Impedance and Voltage Drop

The formula to measure the voltage drop of a busduct is shown below. The impedance and voltage drop values for aluminum and copper conductors are shown in the table below.

The values listed are measured between upper and middle lines at 60Hz. For a 50Hz installation, multiply the reactance (X) by 0.83.

$$V_d = I \times \sqrt{3}(R \cos\theta + X \sin\theta)$$

V_d = voltage drop[V] · I = rated load amperes[A] · R = resistance[Ω] · X = reactance[Ω] / \cos = power factor / \sin = reactive factor

$$\text{Actual voltage Drop} = \alpha \times V_d \times \frac{\text{Actual load current}}{\text{Rated load current}} \times \frac{\text{Actual length of the line (m)}}{100\text{m}}$$

• α (Load Constant) $\alpha = 1$, concentrated load
(a place such as an electrical room)



$\alpha = 0.5$, Distributed load
(a place such as a vertical section)

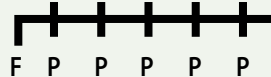

• **F** : Flanged End (panel connections)
• **P** : Plug-in Unit

Ampere(A)	10 ⁻³ Ω / 100m, 60Hz			Voltage Drop(V/100m)				
	R	X	Z	0.7	0.8	0.9	1	
AL	630	13.98	4.07	14.56	13.85	14.87	15.66	15.25
	800	7.97	2.62	8.39	10.32	11.01	11.52	11.04
	1,000	6.83	2.21	7.18	11.02	11.77	12.32	11.84
	1,250	5.55	1.82	5.84	11.22	11.97	12.52	12.01
	1,600	3.82	1.23	4.02	9.85	10.52	11.02	10.60
	2,000	3.08	1.00	3.24	9.96	10.63	11.12	10.67
	2,500	2.40	0.80	2.53	9.74	10.39	10.86	10.40
	3,200	1.91	0.61	2.00	9.82	10.48	10.98	10.56
	3,600	1.72	0.55	1.81	9.99	10.67	11.18	10.74
	4,000	1.54	0.50	1.62	9.93	10.60	11.09	10.64
	5,000	1.15	0.37	1.21	9.24	9.87	10.34	9.94
6,300	1.02	0.33	1.08	10.41	11.11	11.63	11.16	
CU	630	7.49	4.07	8.53	8.90	9.21	9.30	8.18
	800	7.49	3.84	8.42	11.07	11.50	11.67	10.38
	1,000	5.49	2.99	6.25	10.35	10.72	10.82	9.52
	1,250	4.39	2.45	5.03	10.44	10.78	10.86	9.50
	1,600	3.10	1.71	3.54	9.40	9.72	9.80	8.60
	2,000	2.40	1.35	2.76	9.17	9.46	9.53	8.32
	2,500	1.86	1.05	2.13	8.87	9.16	9.22	8.06
	3,200	1.54	0.85	1.76	9.34	9.66	9.75	8.55
	3,600	1.35	0.74	1.54	9.20	9.51	9.60	8.42
	4,000	1.20	0.67	1.37	9.13	9.42	9.49	8.29
	5,000	0.93	0.52	1.06	8.84	9.13	9.19	8.03
6,300	0.73	0.39	0.83	8.62	8.93	9.02	7.97	
7,500	0.62	0.35	0.71	8.83	9.12	9.18	8.02	

Technical Data

Short Circuit Strength

LS C&S Busduct has been tested under actual short circuit conditions according to IEC 61439-1 and 6 [(previous standard) IEC 60439-1 and 2] at KEMA and ASTA. The result and the graph are shown below.

Phase to Phase Short Circuit Ratings

Ampere(A)	AL (kA)		CU (kA)	
	1 sec	3 sec	1 sec	3 sec
630	24	14	36	21
800	42	24	36	21
1,000	50	29	51	29
1,250	62	36	65	37
1,600	95	55	95	55
2,000	121	70	129	75
2,500	132	76	150	107
3,200	169	97	191	110
4,000	200	140	200	149
5,000	200	150	200	200
6,300	200	150	200	200
7,500	-	-	200	200

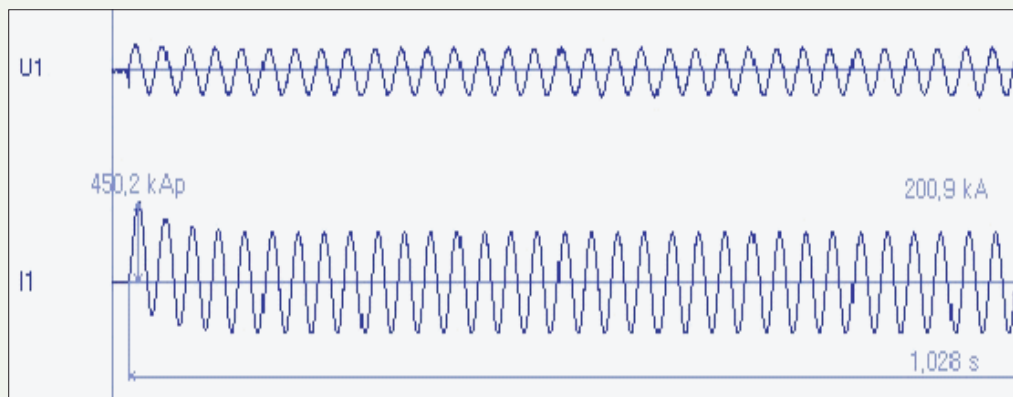

Temperature Rise

The temperature rise limit is an important property which determines the performance of busducts. The temperature rise limit of the busduct is designed that when a busduct is operated with a rated current, the temperature limit values of the housing are within 55K as specified in IEC61439-1 and 6 [(previous standard) IEC 60439-1 and 2].

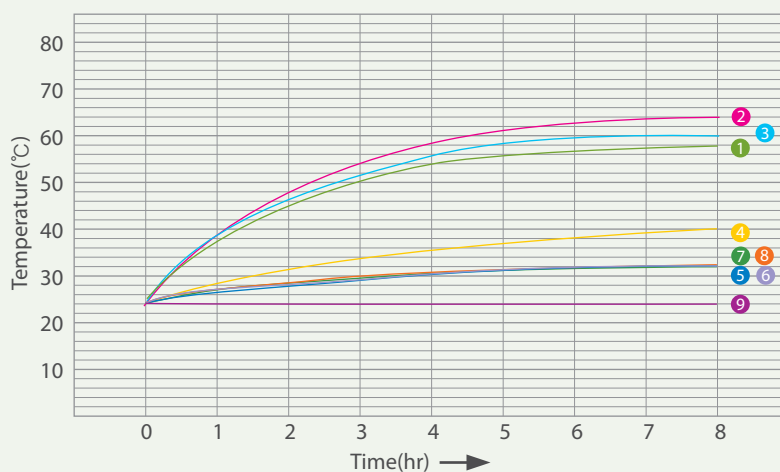
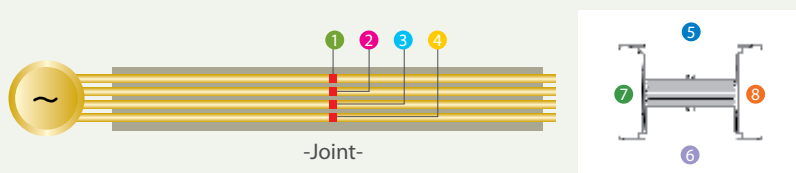

Classification	1	2	3	4	5	6	7	8	9
Sensor Location	Connection Conductor				Housing				Ambient Temperature
Temperature Rise Value	58K	64K	60K	40K	32K	31K	31K	31K	24°C

Joint Connection



Both parts should be aligned at the top and the bottom and the left and the right as well as horizontally and vertically. (This also applies to the joint connection of the horizontal and vertical ducts.) Make sure that the joint kit is not tilted. (We recommend a jig tool for the installation.)

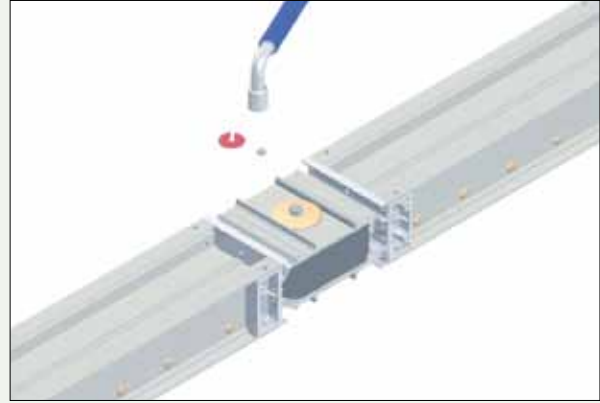

Using a torque wrench, slowly tighten the exposed bolt head of a double headed bolt. The head of the double headed bolt is designed to break off at 800~1000Kgf·cm. Continue tightening the exposed head until it breaks off.

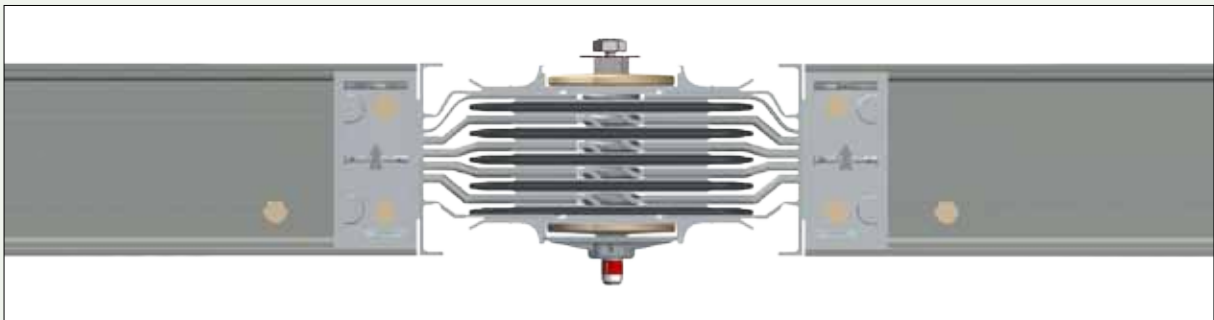

Once the exposed head and the red tag attached to it have been cut off, a red line should be visible, which means they are properly connected. Be sure to check the distance from the housing, and the gaps between the conductors at the kit after the installation.

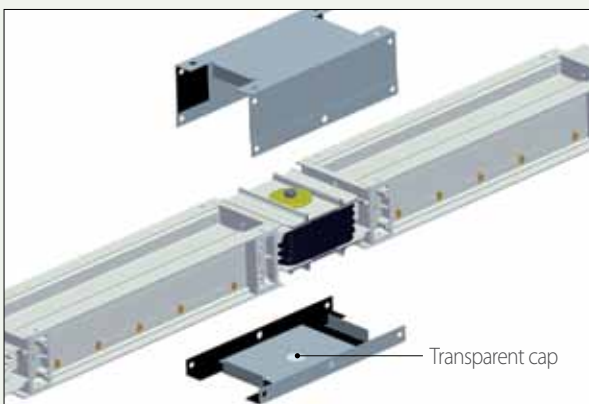

Before applying the connection cover, check the space between the end block and the holes of the connection cover. The red line should be visible through the transparent cap.

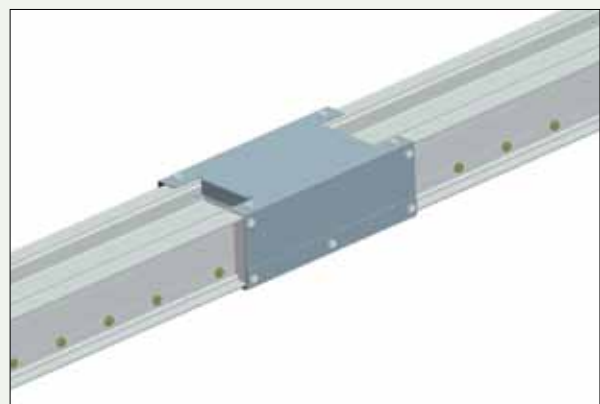

Perform the last inspection of the connection.

Certification & Specification



ASTA Certification (Ez-way)



ASTA Certification (Ex-way)



KEMA Certification (Ex-way)



KS Certification (E-series)



UL Certification (Ex-way)



CCC Certification (E-series)



Dust and Water Proof Certification (E-series)



Fire Proof Certification (Ef-way)



Fire Sprinkler Certification (Ef-way)

Global Network

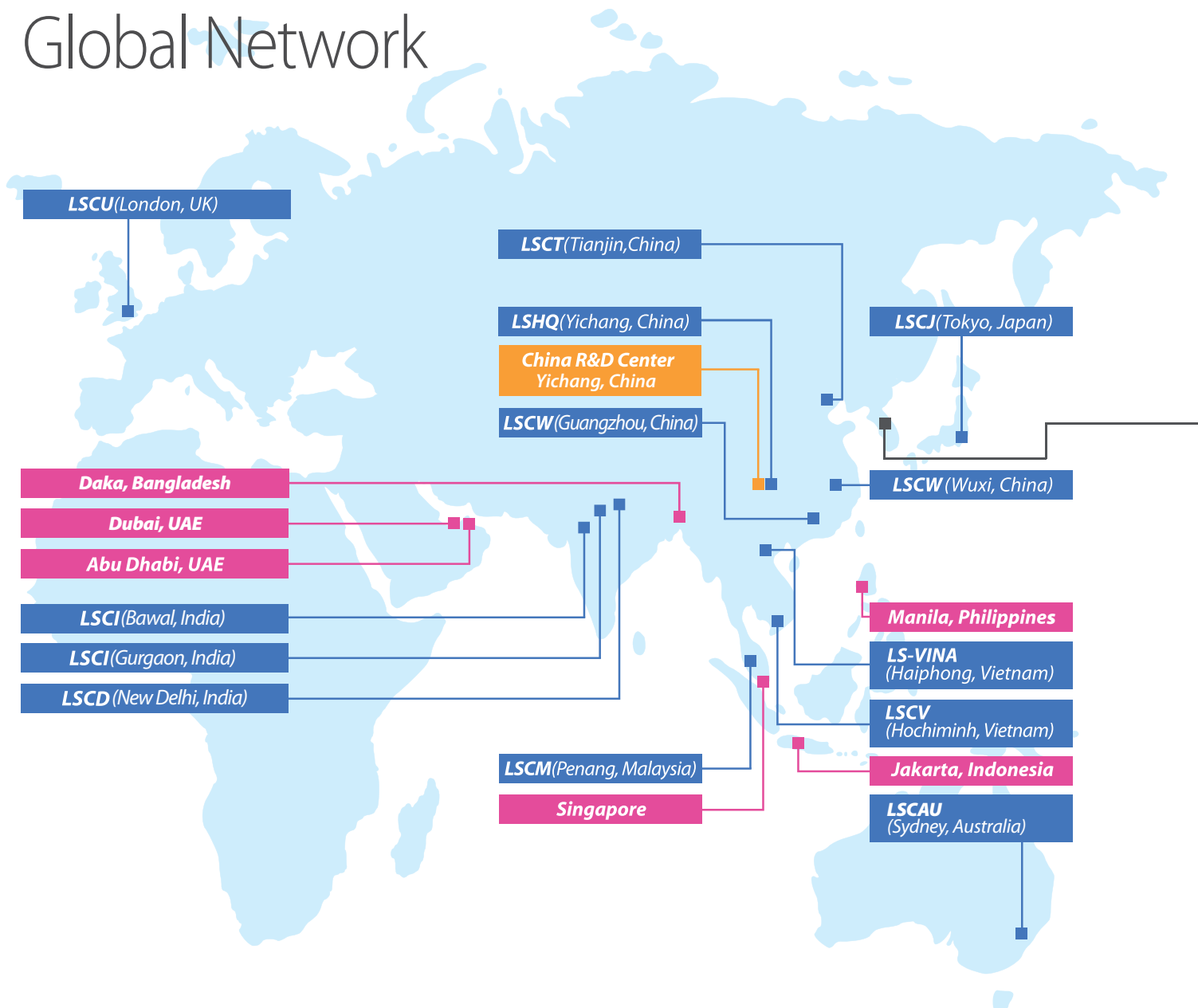

Branches

Abu Dhabi Office(U.A.E.)

Tel. +971-4-344-4662 Fax. +971-2-674-8781

Dubai Office(U.A.E.)

Tel. +971-4-344-4662 Fax. +971-2-674-8781

Singapore Office(Singapore)

Tel. +65-6342-9162-3 Fax. +65-6342-9165

Lima Office(Peru)

Tel. +51-1-434-6433

Jakarta Office(Indonesia)

Tel. +62-21-797-4140 / 4013 Fax. +62-21-799-3071

Manila Office(Philippines)

Tel. +63-917-6272814

Daka Office(Bangladesh)

Tel. +88-015-3410-0356

Subsidiaries

LSCA(U.S.A.) : Marketing and Sales

Tel. +1-201-944-2005 Fax. +1-201-503-8130

LSCAU(Australia) : Marketing and Sales

Tel. +61-2-9460-0255 Fax. +61-2-9460-0355

LSCU(U.K.) : Marketing and Sales

Tel. +44-20-8545-2640 Fax. +44-20-8545-2643

LSCJ(Japan) : Marketing and Sales

Tel. +81-3-6205-7188 Fax. +81-3-6205-7187

LSCD(India) : Marketing and Sales

Tel. +91-11-4106-4242

LSHQ(China)

Tel. +86-717-667-7777

Production : EHV, LV/MV, Overhead Transmission Line, Industrial Specialty Cable & System

LSCT(China)

Tel. +86-22-2699-7618 Fax. +86-22-2695-7617

Production : Magnet Wire

LSCW(China)

Tel. +86-510-8811-9000 Fax. +86-510-8534-5341

Production : Automotive Wire & Cable, Bus Duct, Electronic Wire & Cable, Tube, ACF, Accessories for EHV Cable System

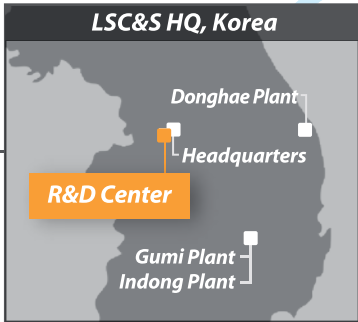
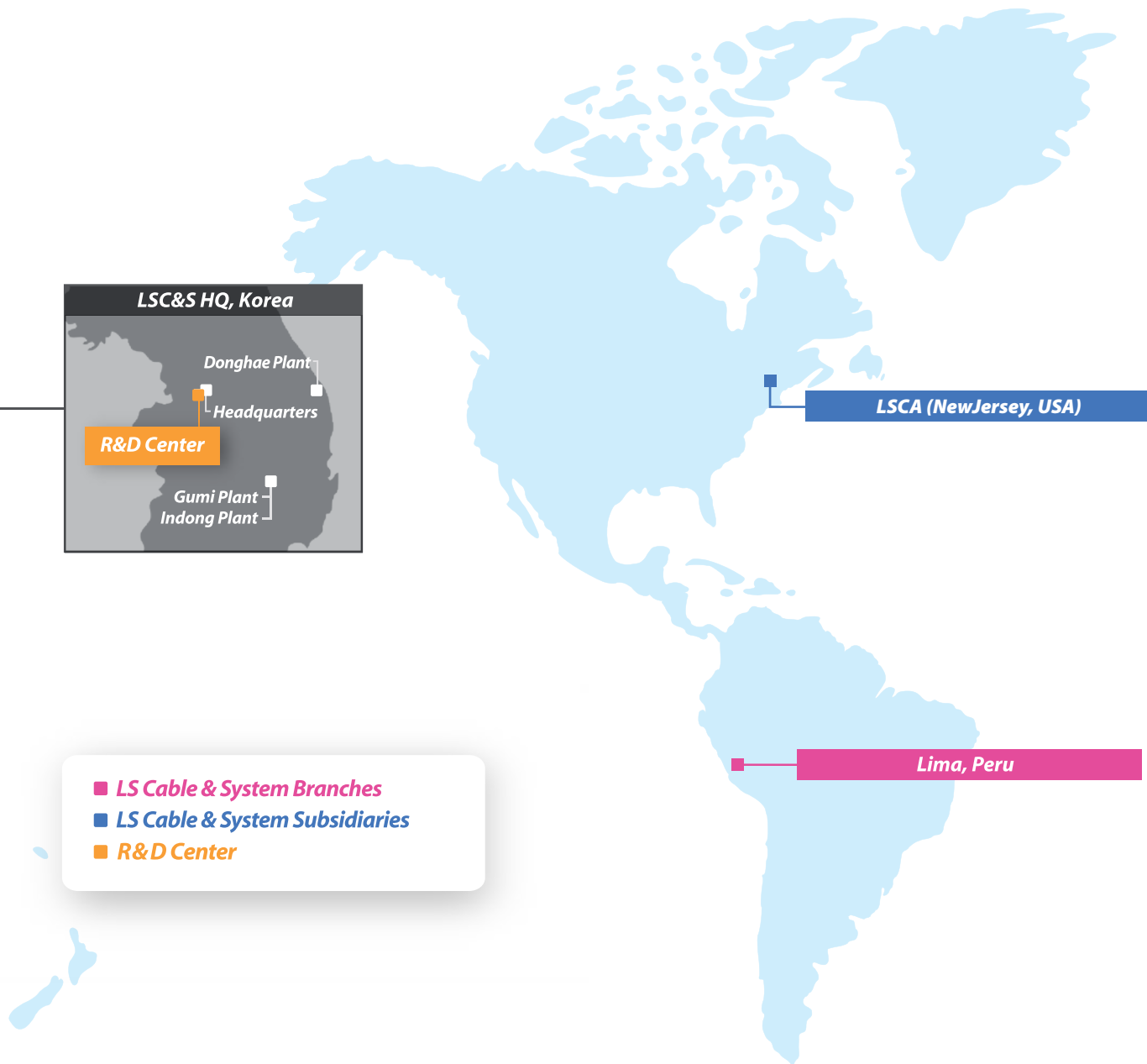

- **LS Cable & System Branches**
- **LS Cable & System Subsidiaries**
- **R&D Center**

Beijing Office(Beijing)

Tel. +86-10-5761-3166 Fax. +86-10-5761-3160

Shenzhen Office(Shenzhen)

Tel. +86-755-8275-0470~1 Fax. +86-755-8275-0545

Guangzhou Office(Guangzhou)

Tel. +86-20-8326-6321 Fax. +86-20-8326-6270

LS-VINA(Vietnam)

Tel. +84-31-354-0141 Fax. +84-31-354-0142

Production : EHV, LV/MV, ACSR, OPGW, SCR

LSCV(Vietnam)

Tel. +84-61-356-9140 Fax. +84-61-356-9148

Production : Low Voltage Cable, UTP

LSCM(Malaysia)

Tel. +60-4-588-9609 Fax. +60-4-588-9607

Production : Magnet Wire

LSCI(India)

Gurgaon: Marketing & Sales

Tel. +91-124-428-5800~4 Fax. +91-124-428-5805

Bawal

Tel. +91-128-426-4267 Fax. +91-128-426-4364

Production : RF Feeder Cable, Network Solution, EHV, LV/MV, OPGW

China R&D Center

Tel. +86-717-667-7777

Korea Operations

Headquarter

Tel. +82-2-2189-9114

Gumi Plant

Tel. +82-54-469-7114

Production : Power Cable up to 500kV, OHTL, OPGW, Data Cable, RF Feeder System, Copper Rod, Magnet Wire

Indong Plant

Tel. +82-54-469-1053

Production : Industrial Cable & Module, Optical Cable, Aluminum Materials

Donghae Plant

Tel. +82-33-820-3114

Production : Submarine Cable, Industrial Specialty Cable

R&D Center

Tel. +82-31-450-8114

Greater Value Together
LS Cable & System

LS Cable & System
www.lscns.com

LS Busduct System

12F, LS Tower, 127 LS-ro, Dongan-gu, Anyang-si, Gyeonggi-do, 14119, Korea
Tel. +82-2-2189-9669 Fax. +82-2-6969-5424